

R. L. ...

# CITROËN

HYDRAULIC

COURSE NOTES

N° 843

## HYDRAULIC COURSE NOTES

1 GENERAL DETAILS



2 « D » VEHICLES



# PRACTICAL REPAIR RECOMMENDATIONS

## I - CLEANLINESS

To function properly, the hydraulic circuits on these cars require absolute cleanliness of the hydraulic fluid and units

### 1. Cleanliness of work :

Before any work is carried out, protectors must be put in place :

- covers of cloth or leathercloth on the front wings, the trim panels of the doors, and the seats,
- a steering wheel glove,
- covers for the sidemember trims ( PALLAS models ).

### 2. Cleanliness of the units :

To avoid the ingress of dirt to the units :

#### a) Before dismantling :

- carefully clean the area in which work is to be done,
- clean the unions and pipe-ends to be disconnected using alcohol for LHS 2 and white-spirit or petrol for LHM circuits.

#### b) After dismantling :

- plug all metal pipe-ends and apertures in units with special plugs sold by the Replacement Parts Department.
- protect the flange unions of pipe assemblies with self-adhesive tape; also the plastic pipes may be dealt with in the same way.
- protect rubber pipe-ends by plugging with a suitable sized object (e.g. a cylindrical pin ).

#### c) Rebuilding :

- clean the pipe assemblies and unions to be replaced with alcohol for LHS 2 and white-spirit or petrol for LHM circuits.
- do not remove the plugs from pipes and units until the very last moment.

### 3. Cleanliness of the fluid :

Never re-use fluid that has been in service

## II.- DIFFERENT TYPES OF PIPING

### 1. Metal piping :

There are three sizes of metal pipe :

- 4.5 mm external diameter
  - 6.35 mm external diameter
  - 3.5 mm external diameter
- Only use standard pipes as supplied by the Replacement Parts Department; except for the longitudinal pipes running the length of the chassis; all the pipes are pre-shaped ready to be fitted.

Pipes which have been pressure-tested are marked with a coloured sleeve. Red for LHS2 systems, and Green for LHM. They must be used only on cars using the appropriate fluid.

- No repairs whatever may be carried out on these pipes for reasons of safer) and reliable service ( e.g. brazing. sleeving, non-standard end fittings ).

## 2. Plastic Piping

- These pipes are used for seepage returns (e.g. Suspension cylinder returns, height corrector returns, etc.) and for petrol supply.
- It is permissible to repair these pipes by sleeving. providing that a pipe does not have more than two sleeves which must be at least 800 mm apart. The sleeve must be glued and when the glue has hardened the joint so made. must withstand 5k,g cm2 ( 72 psi ) pressure from a compressed air line.
- The glue to be used is RILSAN cement. Sold by Etablissements BOYRIVEN, 37 bis avenue de Villiers - NEUILLY-SUR-SEINE.

## 3. Rubber piping :

These pipes are used for the operational returns from units, the supply from the reservoir to the High Pressure Pump, and some seepage returns.

- All these pipes are marked Red or Green in accordance with the fluid which they are to be used, LHS2 or LHM respectively.

## III - STORAGE OF UNITS

Units must be stored full of fluid and firmly plugged, protected from dust and knocks. Parts must be used in strict rotation so as to keep parts in stock for the minimum time possible.

Rubber seals and pipes must be stored away from dust, light, and heat

## IV DIFFERENT METHODS OF SEALING

### 1, Sealing by metal clip :

This method of sealing is used to secure rubber pipes onto steel and plastic pipes and unions.

- When fitting :
- place a rubber protective ring under the clip
  - take care not to cut the end of the pipe

### 2. Rubber Sleeve Seals :

These seals ensure the sealing of steel pipes fitted to hydraulic units

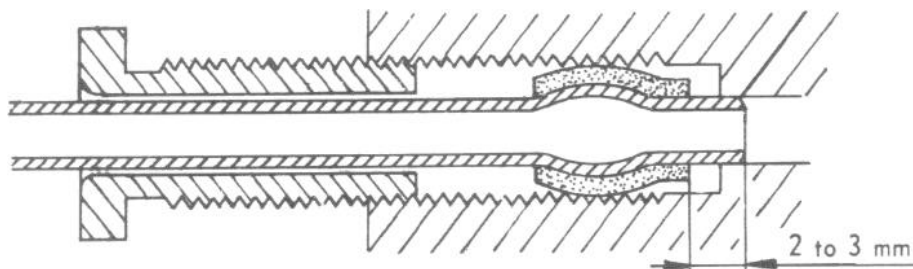

- Sealing is achieved by the deformation of the sleeve under the action of pressure
- The seals must be replaced every time a pipe is disconnected.
- Do not forget to remove the old seal, then clean the bore before rebuilding.

- Always fit the seal to the pipe dry, so that about 2 mm of the pipe projects through the seal. Centralise the pipe in the bore and ensure that the pipe goes fully home.
  - The swelling near the end of the pipe holds the seal in place.
  - Start the union nut by hand and tighten moderately ( 1 m.kg ) ( 15 ft.lbs ).
- Seals to be used with LHS2 are painted Red. Those for use with LHM are Green.

### 3. Ring seals :

- Sealing is ensured by the deformation of the seal under the influence of the fluid under pressure. In order that the pressure may achieve this, the diameter of the ring is less than the width of the groove and greater than its depth.

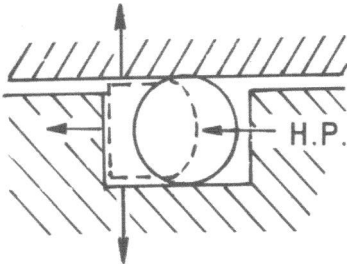

- Three types of ring seals are employed :
  - Marked Red for LHS2
  - Marked Green for LHM
  - Marked White for either
- Seals with White markings are only used between static components.
- The marking on a seal must always face in the direction from which the pressure is coming. In addition the seals must be soaked in the appropriate fluid before fitting.

### 4. Sealing Plates :

These are found at flange joints between pipes and units

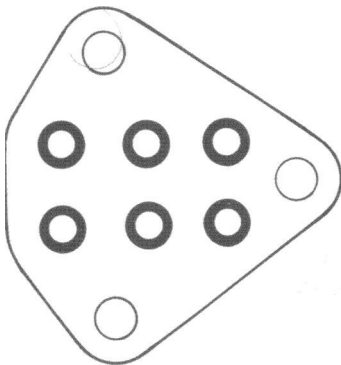

- When fitting, ensure that the holes in the plate correspond with those in the flange.
- The plates and the seals are sold separately.
- The seals are marked with White and are fitted to vehicles using either type of fluid. They must be replaced at each dismantling.

### 5. TEFLON Seals :

- These ensure sealing of items subject to large or frequent movements ( e.g. hydraulic steering-rack piston, suspension cylinder ).
- Teflon seals may be used with either type of fluid.

### 6. Identification of Seals :

- Workshop sheets, available from the Replacement Parts Department, show clearly which seals (Red, Green, or White ), are necessary in the course of repairs or the overhaul of a hydraulic unit.

## V - HYDRAULIC FLUIDS

### 1. LHS 2 ( From September 1964 to September 1966 ).

This fluid is almost colourless, having a slightly amber tinge. Its smell is reminiscent of ammonia. It must not be used on vehicles with master-cylinder braking systems. ( it causes deterioration of the rubber cups ).

### 2. LHM ( Since September 1966 )

This fluid is green in colour. It is of mineral origin, and is similar to engine oil.

NOTE : From September 1966 to December 1968, LHS2 was still supplied in vehicles for the U.S.A. and CANADA.

### 3. Contents of the systems :

D Vehicle ( Hydraulic gear change )	10 1/2 Imp. pints
D Vehicle ( Manual gear change )	8.8 Imp. pints
SM Vehicle	9 3/4 Imp. pints
GS Vehicle	6 1/4 Imp. pints

### 4. Draining the system

The system should be drained and refilled with fresh fluid every 18.000 miles.

Drain after causing the greatest possible amount of fluid to return to the reservoir. ( Suspension in low, main and brake accumulators empty ).

### 5. Cleaning the filter :

The filter must be thoroughly cleaned every 6.000 miles ( A clogged filter leads to inefficiency of the hydraulic system ).

The filter should be cleaned in alcohol ( LHS2 ), and white-spirit or petrol ( LHM ), and then blown through with compressed air.

### 6. Advice in the event of fluids being mixed ( See Information Bulletins n° 32 and 72 ).

An accidental mixture of fluids in the hydraulic systems ( LHM in an LHS2 vehicle, or vice-versa ) causes a rapid deterioration of all the rubber parts in the system ( Seals, diaphragms, etc. ) The severity of this deterioration is a function of the amount of fluid mixed, and the length of time that the vehicle is operated with this mixture.

1°) In the event of a recent mixture of fluids, if there appear to be no malfunctions of the hydraulic system, drain the system after returning as much fluid as possible to the reservoir. Then flush the system using Hexylene-Glycol for LHS2 vehicles, and normal flushing oil for LHM vehicles. Check the suspension spheres, main accumulator and brake accumulator, for pressure and verify that the diaphragms are not deteriorating. If they are within the specified limits, refit these units. Refill the reservoir, bleed a large amount of fluid through the braking system; do not re-use the fluid bled off. Then check the action of the suspension and the brakes. Allow the vehicle to be used for about a week.

Check at frequent intervals that the suspension and brakes are functioning correctly.

After two weeks use, drain, refill and bleed the system again.

2°) If a vehicle has been used for a considerable time with a mixture of fluids, malfunctions will be found in the hydraulic system. The majority of the rubber parts will have deteriorated. Take off all the hydraulic units and change all the seals and rubber parts. Change the main and brake accumulators, also the suspension spheres. Flush out all the units and piping with petrol, then alcohol for LHM vehicles and with alcohol with-spirit or petrol and again with alcohol for vehicles using LHS2. In both cases, blow through with compressed air. Change all rubber pipes and dust protectors.

## DISTRIBUTION AND REGULATION PRESSURE

This chapter is independant of the hydraulic system or units of the 'D' models. The pressure distributors and regulators arc integral parts of many of the hydraulic units. It is therefore essential to know their principles of operation to understand the working of the units.

### I - PRESSURE DISTRIBUTOR

A pressure distributor is a tap which will admit or exhaust fluid under pressure to or from one or more circuits.

A distributor may also isolate this unit or units from both the inlet and exhaust lines.

The pressure distributor is generally a slide-valve operating in a sleeve. Only the position of the slide-valve is the controlling factor of the operation of the circuits.

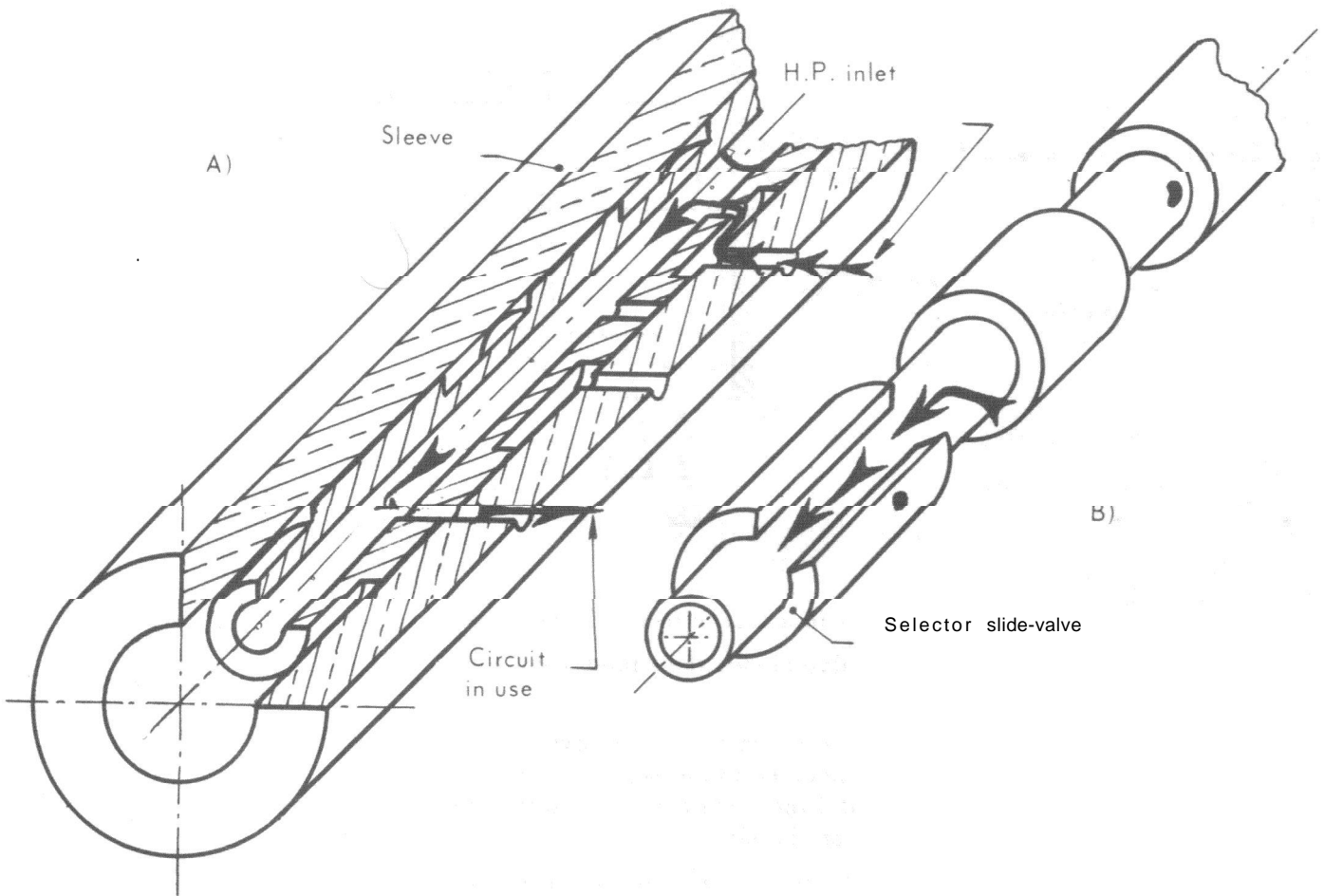

The gear selector slide-valve is hollow, and has 1 inlet for the supply of the fluid at High Pressure and 5 outlets (1 for each gear) to supply the gears.

Longitudinal and circumferential grooves machined in the slide-valve allow the fluid to return to the reservoir from the various circuits.

The sleeve has 5 ports, one to supply each gear.

- **With the valve at rest** ( Neutral ) the various outlets from the slide-valve align with a plain part of the sleeve. The various ports of the sleeve communicate with the reservoir via the grooves in the slide-valve,

- **Pressurisation** ( Diagram A ) When the slide-valve is moved, a a port is aligned in the latter with a corresponding port in the sleeve and the circuit is pressurised.

- **De-Pressurisation (Diagram B)** : With the slide-valve in any position which allows alignment of an outlet to a circuit to communicate with the return to the reservoir, the fluid under pressure in that circuit will flow out and return to the reservoir.

NOTE : The operation of this distributor is independent of the amount of effort applied to the slide-valve when it is being moved. Only the movements and positioning of the latter permit the distribution of fluid.

A further type of pressure distributor : The height correctors, the operation of which is given on page 30.

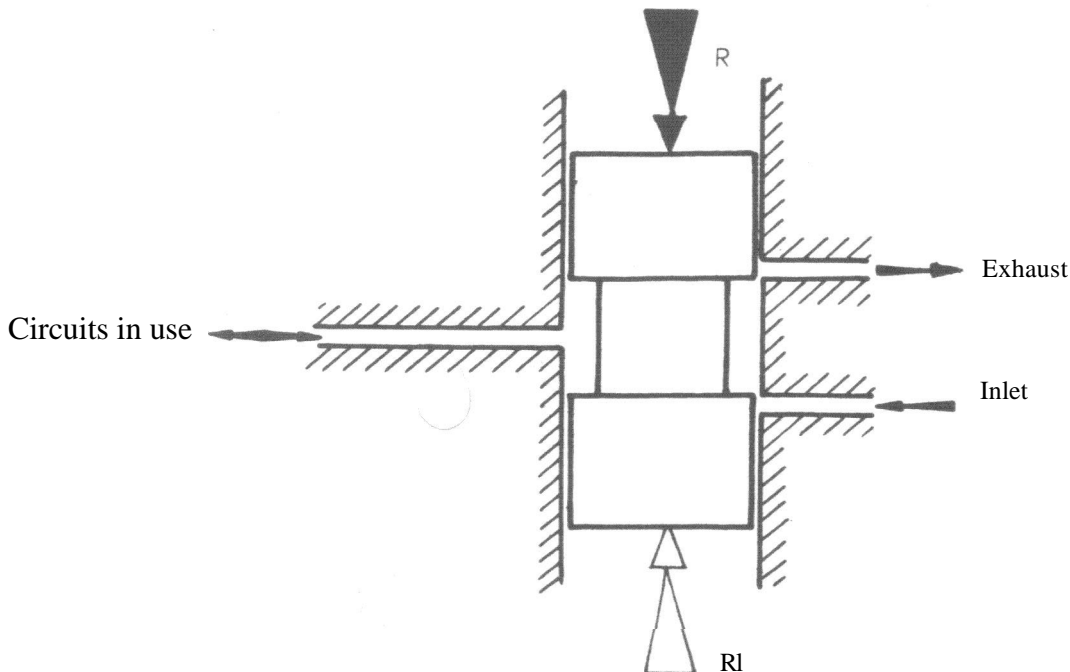

A slide-valve with two shoulders slides in a sleeve in which there are three ports.

- In the « neutral » position the slide-valve closes the « inlet » and « exhaust » port. The supply port to the circuit is always open.
- **Pressurisation** : For the slightest effort « R » on the slide-valve, it will move so that the « inlet » port is opened. The circuit is then connected to the source of pressure. Thus the pressure in the source of pressure circuit will enter the circuit in use and the pressure values in two circuits will be equal regardless of the effort on the slide-valve.
- **De-pressurisation** : On the other hand a force R.1 (opposed to R) applied to the slide-valve will move it so that the « exhaust » port is opened. The fluid under pressure in the circuit in use will flow out and return to the reservoir.

NOTE : The forces R and R.1 are connected with the operation of the slide-valve only by the presence of a dash-pot in the height corrector.

Sometimes hydraulic units can only be made to operate by using a pressure lower than that in the Source and Pressure circuit.

In some cases it is necessary to use :

- A variable but controllable pressure ( steering, braking, etc. )
- A constant but relatively low pressure ( clutch )

A simple pressure distributor cannot fulfil these conditions.

A pressure control-valve makes it possible to supply these different units correctly.



## II - PRESSURE CONTROL - VALVE

### 1. Description

The diagram below shows the various parts which comprise the pressure control-valve. The force  $R$  applied to the end of the slide-valve may be the strength of a spring, the effect of the different calibrations of several springs, or a physical effort.

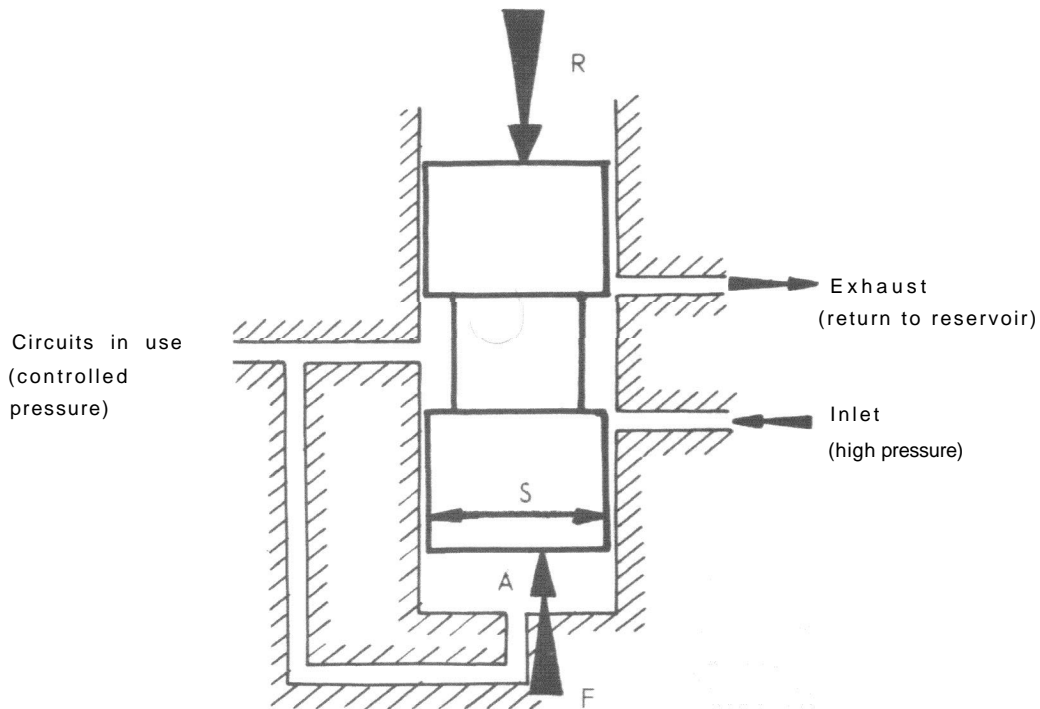

### 2. Operation

#### a) Pressurisation

To make the control-valve operate it is necessary to connect the source of pressure with the circuits to be used.

This operation may be :

- Automatic : at rest the source of pressure is connected to the circuit.
- Controlled manually : at rest the position of the slide-valve is not important.

When pressure rises in the circuit in use : this very pressure  $P$  rises also in the chamber  $A$  under the slide-valve.

A force  $F = P \times S$  opposes the force  $R$ . (  $S$  = The surface area of the slide-valve ).

#### b) Equilibrium

When  $F$  becomes equal to  $R$  the slide-valve takes up a position of equilibrium in which both the 'inlet' and 'exhaust' ports are closed

The pressure in the circuit is therefore limited to a value.

$$P = \frac{R}{S}$$

This pressure is independent of that existing in the source of pressure circuit. If the force  $R$  is increased, the controlled pressure rises, and vice-versa.

For a fixed value of R :

- If the pressure drops in the circuit being used, F decreases, R prevails, the slide-valve moves to the « inlet » position, and the regulated pressure  $P_r$  increases ( Figure A.).
- If the pressure rises in the circuit being used, F increases, the slide-valve moves to the « exhaust » position and the pressure decreases ( Figure B ).
- These two possibilities, resulting from seepage and friction between the slide-valve and its sleeve, result in the regulated pressure oscillating between two values very-near the theoretical pressure.

$$P_r = \frac{R}{S}$$

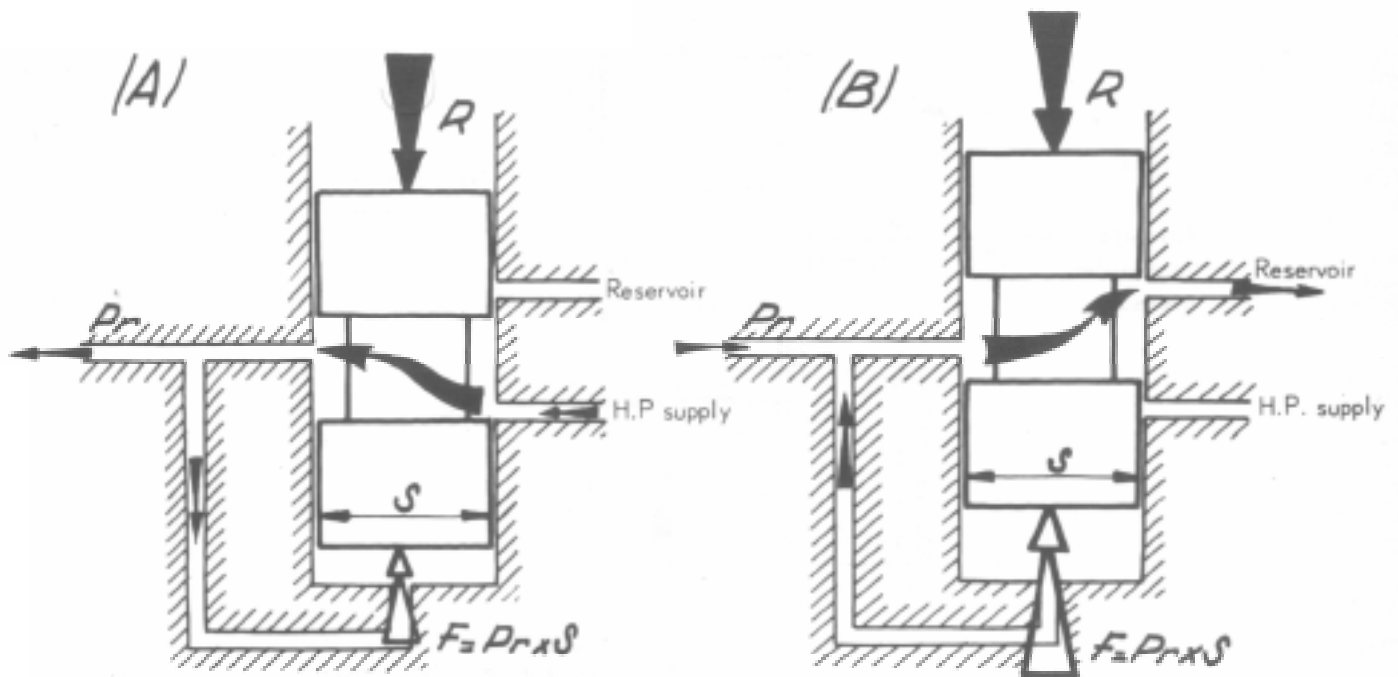

c) Applications :

- If R is the calibrated strength of a spring T, a regulated pressure is obtained :

$$P_r = \frac{T}{S}$$

Example : Automatic gear change slide-valve in the gear selector.

- If R is a variable manual force, or the variable calibration of a spring ( the calibration varying with the movement of the spring's abutment ) a pressure is obtained which is proportional to the force R.

This is therefore an « adjustable » regulator.

Example : Hydraulic brake control, Centrifugal Regulator.

d) Dash-pots :

To avoid a rise of pressure which is too rapid in the circuit in use the movement of the valve may be slowed down by the use of a dash-pot.

This method also avoids oscillation of the slide-valve.

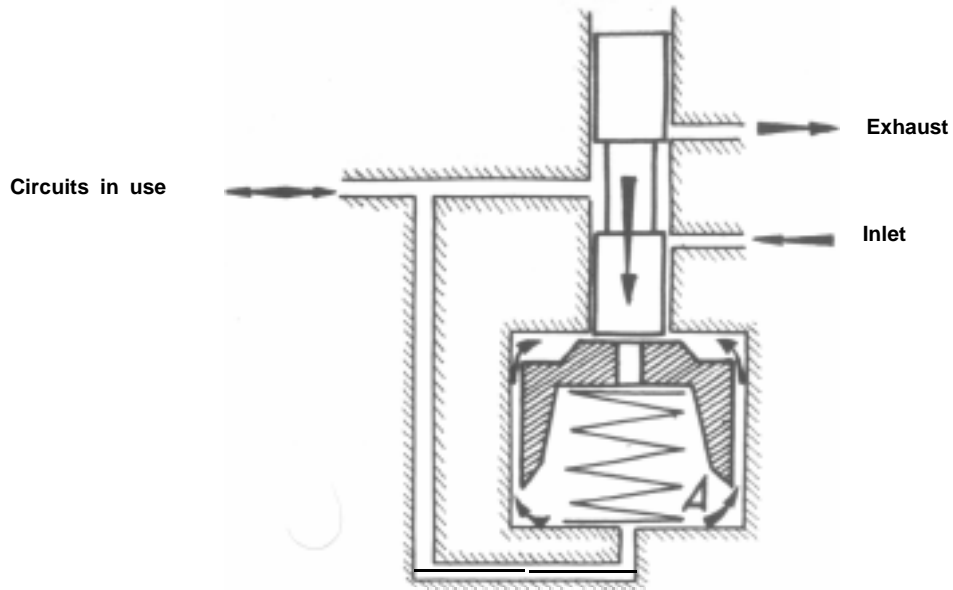

A piston with a calibrated amount of clearance slides in the chamber **A**, the diameter of which is greater than the slide-valve.

When the slide-valve moves down, the fluid is restricted in its movement between the piston and the walls of the chamber **A**, which slows down the movement of the valve.

A weak spring and a hole drilled in the head of the piston allow a rapid return of the slide-valve.

» D » VEHICLES

SOURCE OF PRESSURE

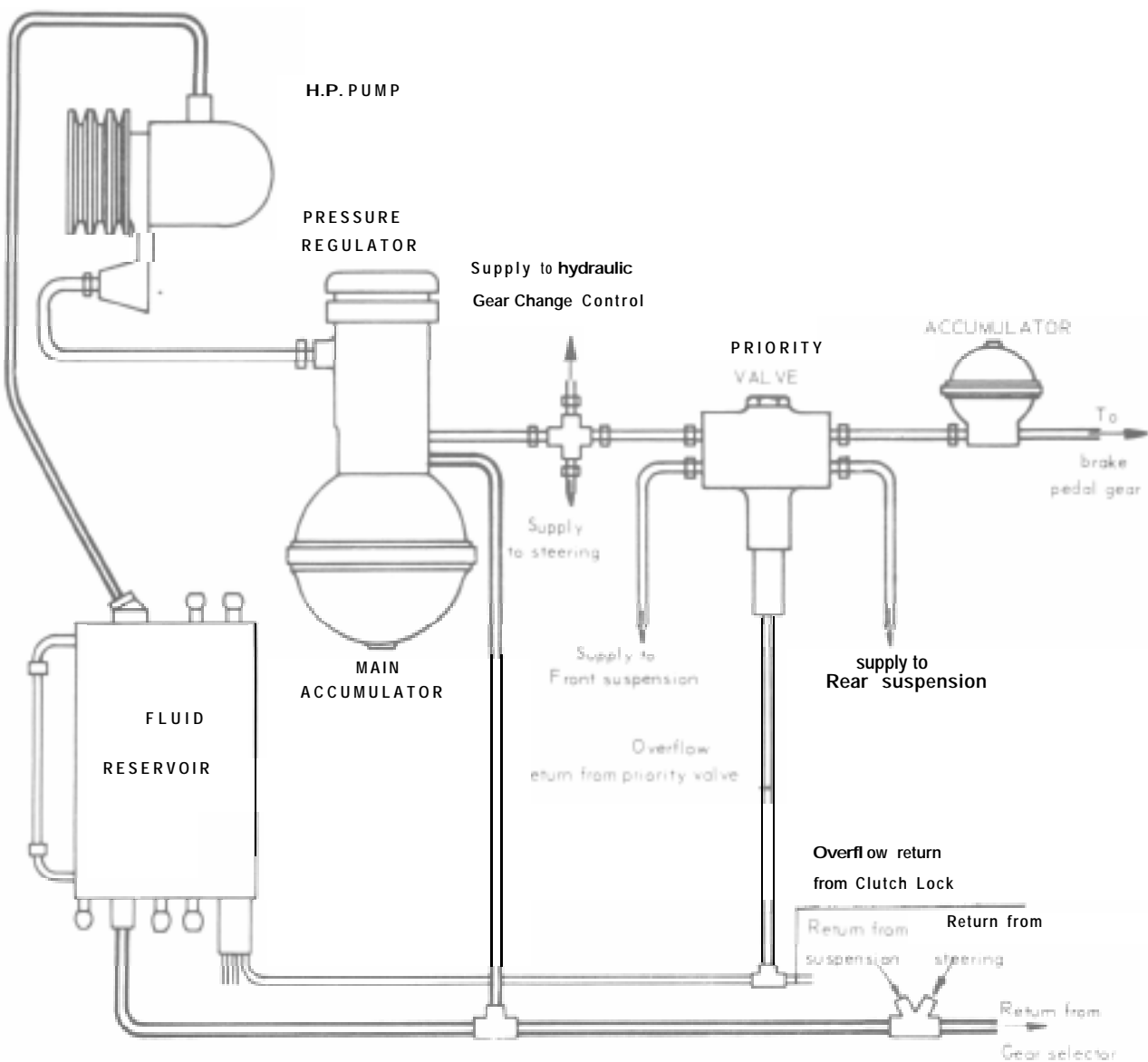

SOURCE OF PRESSURE CIRCUIT

## SOURCE OF PRESSURE

### I- CIRCUIT LAYOUT

- The units comprising the source of pressure are as follows :
  - The hydraulic reservoir
  - The high pressure pump
  - The high pressure regulator
  - The main pressure accumulator

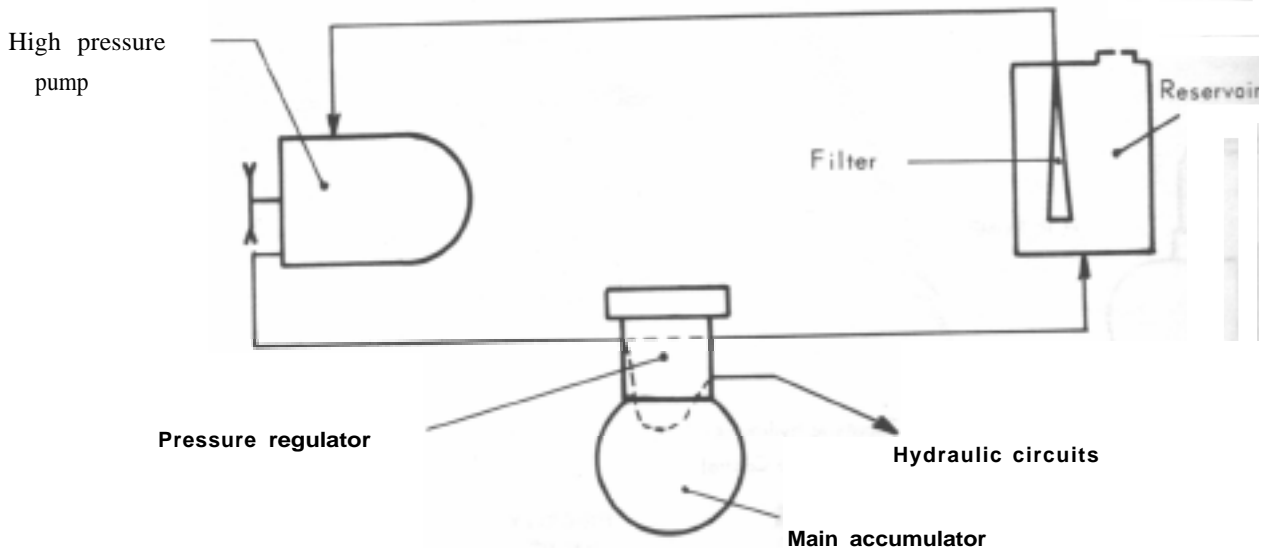

- To ensure the correct operation of all the hydraulic units, a certain minimum pressure must be maintained in their supply circuits.  
To avoid making the pump stop and start for each demand of hydraulic pressure, a certain amount of fluid is stored at a higher pressure than the minimum operating pressure.
- As long as the pressure remains between the storage pressure and the minimum operating pressure then the pump draws fluid from the reservoir and returns it without generating any pressure, this is the rest-period for the pump.
- The reserve of pressure is maintained by the main accumulator.
- The maximum and minimum pressures are controlled by the pressure-regulator which causes the flow of fluid to be directed to :
  - either the main accumulator ( pumping under pressure )
  - or the reservoir ( pumping without pressure)

### II - RESERVOIR

1. A metal container with external sight tube showing « max » and « min » levels.
  - The reservoir has an internal baffle to allow fluid returning to the tank to settle and deaerate and to prevent surging. It is vented to atmosphere by a small hole in the filler cap.

A rubber pipe connected to the base of the container facilitates its draining.

- There are two types of reservoirs :

- One for D models equipped with hydraulic gear change and clutch ( DS 23 I.E. - DS23 - DS 20 - DX.IE - DX - DY )
- The other for D models with manual gear change and clutch ( DS 23 I.E. - DS23 - D Super 5 - DX - BW - DX.IE - DJ. DP. DT. DV ).

**2. Connections :**

**a) Reservoir for vehicles with hydraulic control of gear change and clutch.**

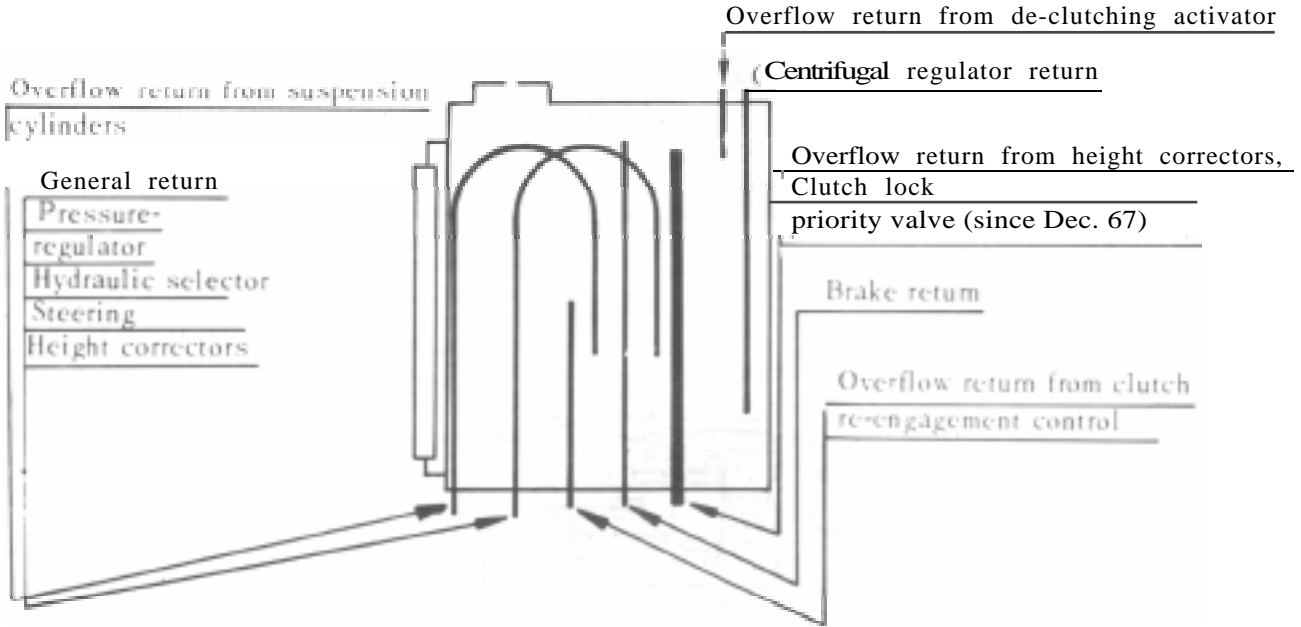

**b) Reservoir for vehicles with manual control of gear change and clutch**

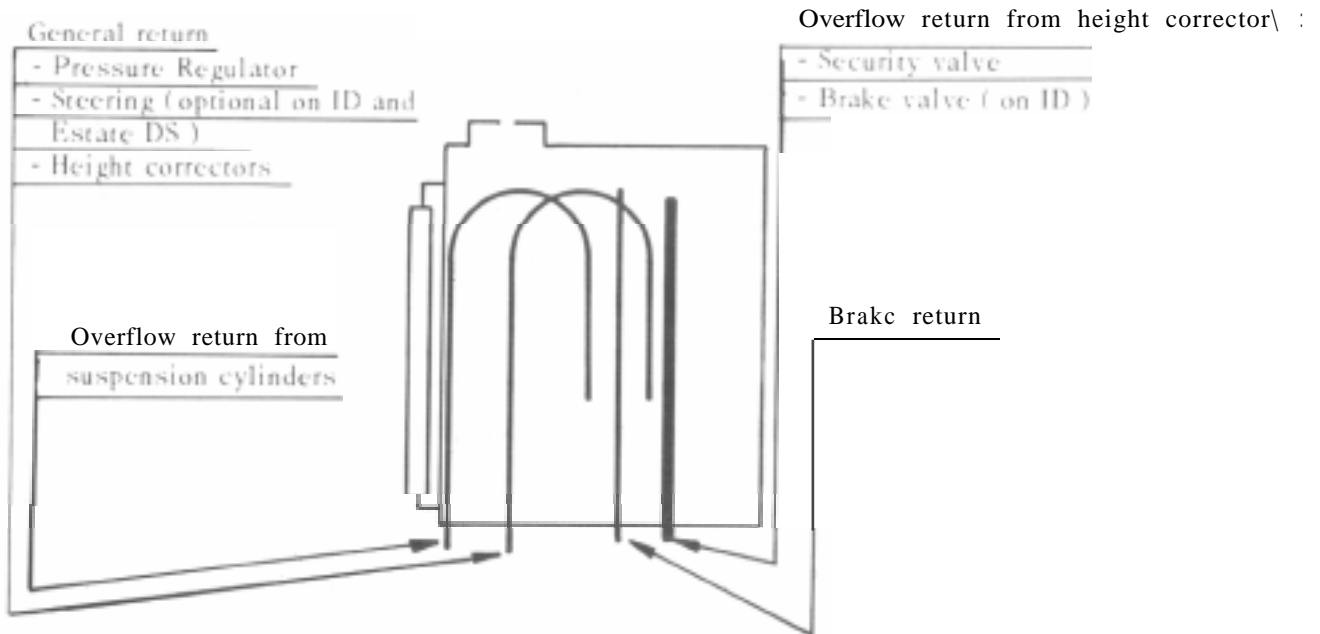

**3. Reading the hydraulic fluid level.**

The hydraulic fluid level is checked with the engine running and the manual height control lever in the « high » position.

### III - HIGH PRESSURE PUMP

- This is a 7 piston volumetric pump : the swept volume remains the same whatever the pressure.
- It comprises several pistons arranged in such a way as to provide a continuous flow of fluid and at the same time provide the necessary pressure on the fluid.
  - The odd number of pistons is due to consideration of hydraulic factors. (Smoother fluid flow ).
  - The number 7 was chosen for reasons of manufacture (diameter of pistons for example) and size.

#### 1. Description :

- The pump comprises 7 identical elements disposed in a circle. A swashplate controls the movement of the pistons by small push-rods.
  - The wall of each cylinder has 4 holes : these are the inlet ports
  - Each element has a non-return valve held on its seat by a spring. All the outlets are inter-connected and are in turn connected to the supply outlet of the pump.
- So that the push-rods are not drawn round, the swashplate is prevented from turning. It gives only an oscillating movement.

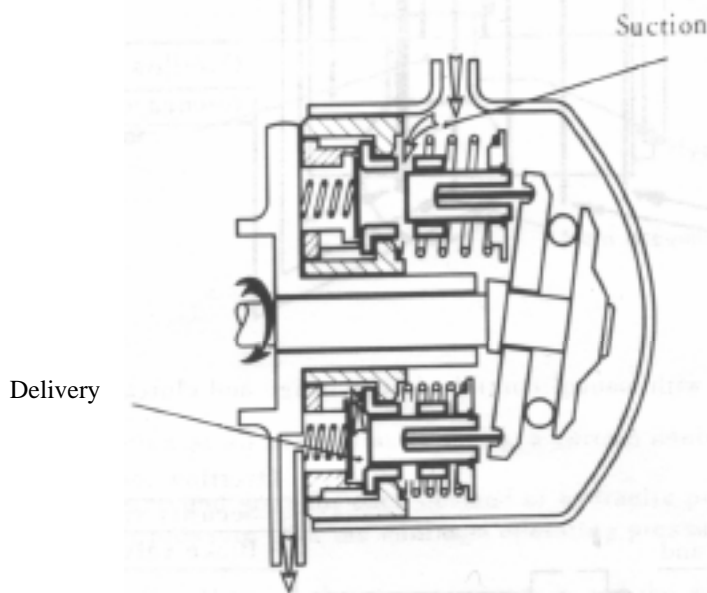

#### 2. Operation :

##### a) Inlet and filling :

- During its return travel imparted by the return spring, the piston causes a depression in the cylinder. When the inlet ports are opened, fluid in the pump body enters the cylinders.
- This depression is communicated to the pump body, ensuring the supply of fluid from the reservoir.

##### b) Compression and delivery :

- Compression starts when the inlet ports are closed.
- When the pressure in the cylinder is greater than that in the system, the non-return valve opens and delivery takes place.
- The non-return valve closes by the action of the spring. The pressure existing in the system holds the valve shut on its seating.

##### c) Piston Travel

- While the pump shaft completes a half turn, the piston is made to move distance which is its total stroke.

- A complete turn of the pump shaft thus gives a complete cycle. ( Inlet and Delivery ) for each piston.

d) **Delivery :**

- The manufacturing tolerances of the pump parts are such that it is necessary to position the piston accurately in its sleeve to obtain the correct delivery.
  - This setting determines the piston stroke, and thus its maximum delivery.
  - The setting consists of allowing a clearance of 0.5 mm between the disc valve and the piston crown. achieved by the use of push-rods of different lengths.
- The pump delivery is 2.80 cc per turn or 840 cc per minute at an engine speed of 600 r.p.m. with a new pump. ( The pump runs at half engine speed ).

c) **Pressure :**

**Minimum pressure :**

- While the pump is idling, the pressure is only enough to return the fluid to the reservoir through the pressure-regulator.

**Maximum pressure :**

- Theoretically there is no limit to the maximum pressure.
- In practice, the maximum pressure is controlled by the pressure-regulator.

## IV.- MAIN ACCUMULATOR

### 1. General Details :

- The accumulator improves the flexibility of the piston.
  - By immediately supplying fluid in the event of a heavy demand.
  - By allowing the pump to idle and eliminating repeated cutting-in and out.
  - By eliminating shocks in the hydraulic system ( As a damper ).
- Since April 1969 the D models may be equipped with either of two types of main accumulator.
  - Machined, forged steel accumulator
  - Pressed steel accumulator

### 2. Description

a) **Forged steel accumulator**

- This is a sphere divided internally in two portions by a flexible diaphragm, one of these portions is filled with nitrogen under pressure, the other, connected to the pressure regulator, receives the fluid.
- **The sphere :** comprises two halves screwed together, the force which tends to separate the two halves is taken by a straight-sided thread.
- **The diaphragm :** made of synthetic rubber, is held between the two half-spheres which ensure a good seal. A metal cup is fixed in the centre of the diaphragm.
- **The nitrogen :** is fed in by way of the hollow filler screw. When no fluid is present it occupies the sphere's whole volume, holding the diaphragm against the sphere and the cup against its seat. The gas pressure is thus the initial inflation pressure of the accumulator.

b) **Pressed steel accumulator :**

- This is also of spherical shape, comprising a pressed steel globe, to which is welded a machined base.
- The diaphragm is held between the sphere and a retaining plate. A plastic cup is fixed in the centre of the diaphragm.
- The nitrogen is introduced into the sphere in the same way as for the previous accumulator, and works in exactly the same way.



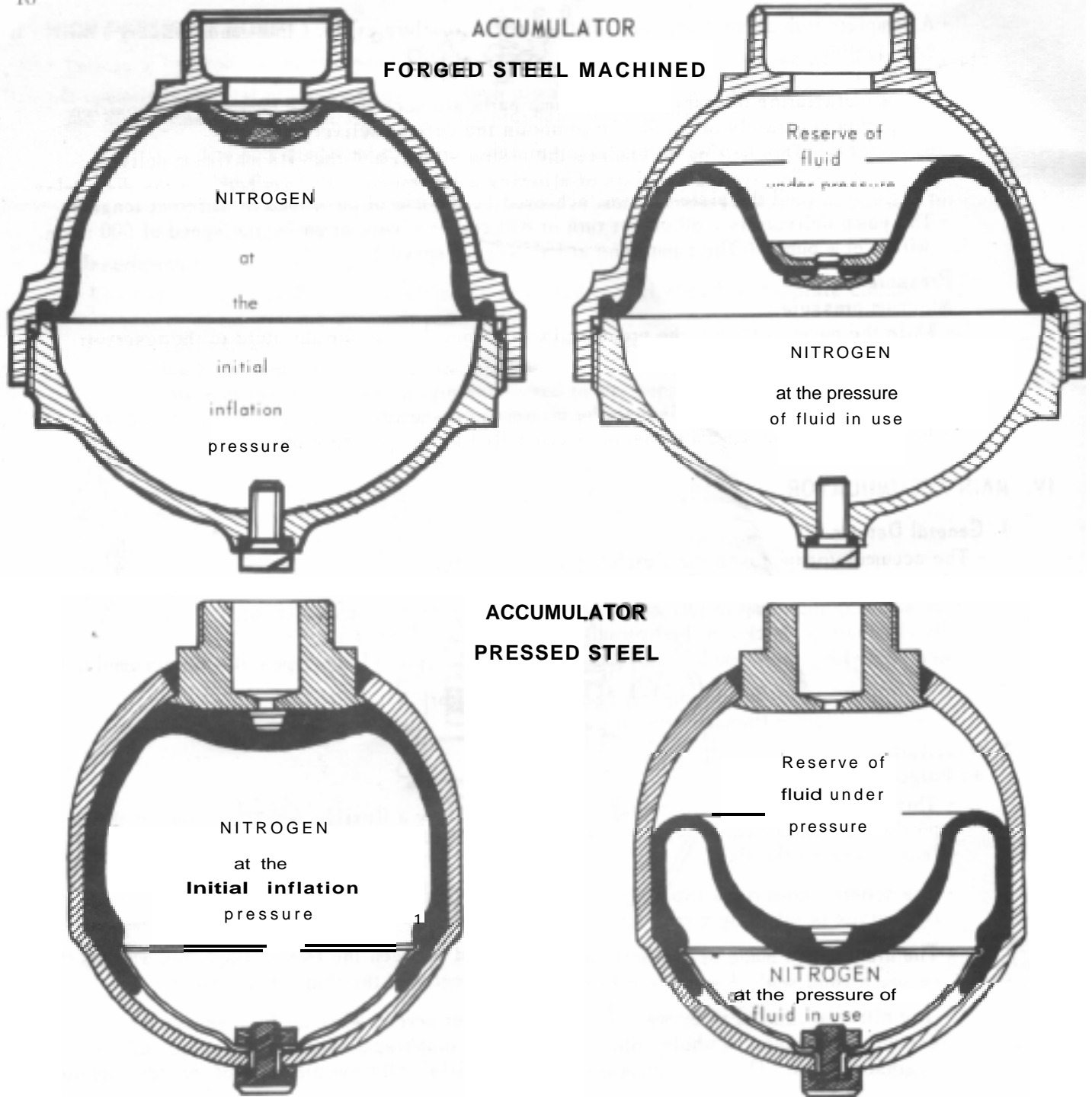

### 3. Particular points :

- When the accumulator contains a reserve of fluid under pressure, the diaphragm is in a certain position and the gas is **compressed** to a pressure higher than that of its initial inflation. On either side of the diaphragm, gas and fluid are at the same pressure and the diaphragm is in a state of equilibrium.
- When fluid is used ( a drop in volume and pressure of **the** fluid) the compressed gas expands to compensate for these changes and the flexible diaphragm takes up a different position of equilibrium. The gas and fluid are still at identical pressures, but of a lower value.
- This condition continues until the initial inflation pressure of the accumulator is reached. Then the diaphragm comes into contact with the shell of the accumulator.
- The accumulators are marked with a number punched on the head of the fillet screw.

- 60 for vehicles with brakc valve system ( since March 1973 )  
 - 65 for other models

## V - PRESSURE REGULATOR

- The pressure regulator controls :
  - A minimum pressure necessary for the correct operation of the units.
  - A maximum pressure to obtain a sufficient quantity of storage in the accumulator, and to limit the maximum pressure supplied by the pump.

CUT-IN

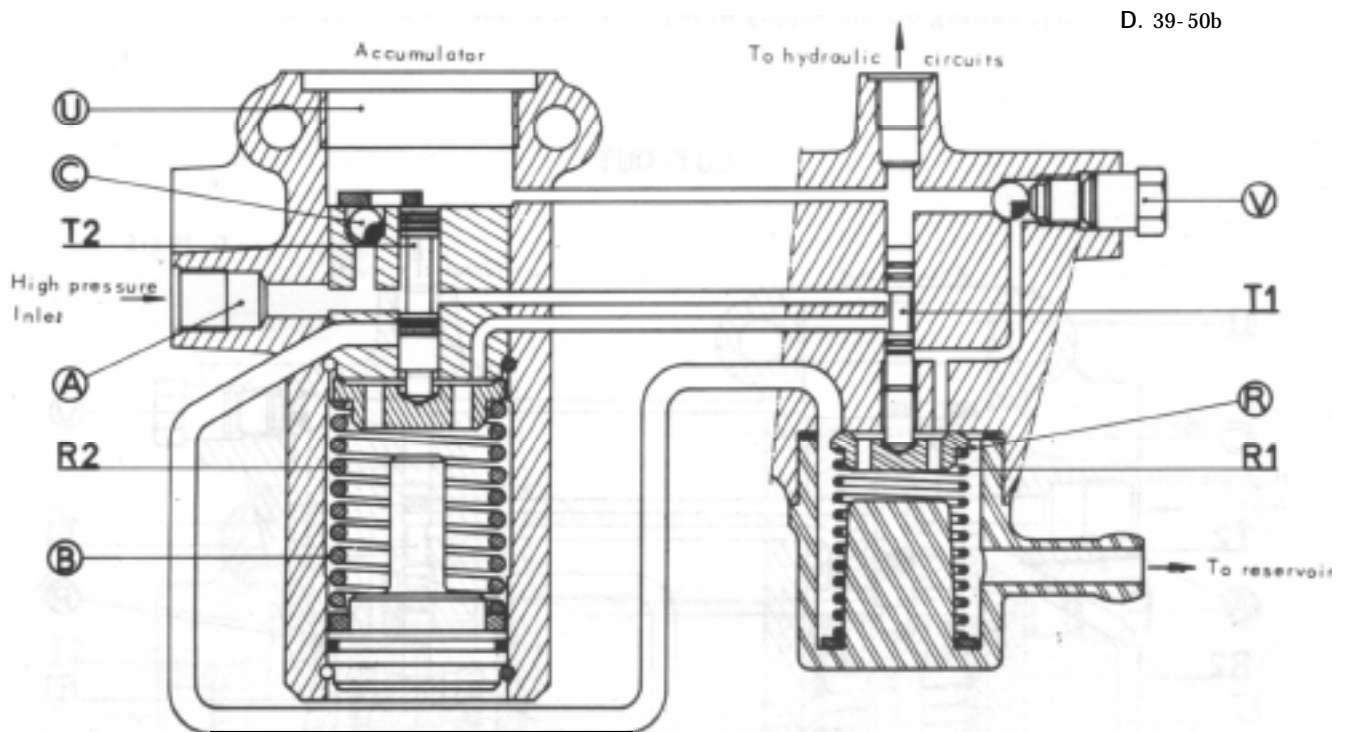

### 1. Description

The Pilot-Valve Regulator comprises basically 4 chambers inter-connected via a non-return valve and two slide-valves.

- Chamber A: connected to the feed from the pump
- Chamber U: connected to chamber A, the accumulator and supply to units
- Chamber B: connected to chamber A or chamber R depending on the position of the pilot valve T.1.
- Chamber R : connected to the fluid reservoir
- Pilot Valve P.1: allows the fluid to flow into chamber B or from chamber B to chamber R,  
It is controlled by the pressure of the fluid in chamber U.
- Slide-Valve T,2: allows fluid to flow from chamber A to chamber R depending upon its position,  
It is controlled by the pressure of the fluid in chambers U and B.
- Non-return Valve C : allows fluid to pass only from chamber A to chamber U.
- Pressure-release screw V : allows the fluid in chamber U to escape back to the reservoir via chamber R, if required,

## 2. Operation :

### a) Rise of pressure

Fluid from the HP pump ( in chamber A ) rises in pressure in chamber U and the supply circuits by lifting the non-return valve C.

This pressure rises simultaneously in chamber B via pilot valve T.1.

### b) cut-out :

The rising pressure in chamber U creates an increasing force  $F$  on the upper face of the pilot valve T.1 which tends to force the slide valve downwards.

As soon as this force  $F$  becomes stronger than force of spring R.1, the pilot valve T.1 moves downwards slightly, cutting off the supply of high pressure fluid to chamber B.

### CUT -OUT

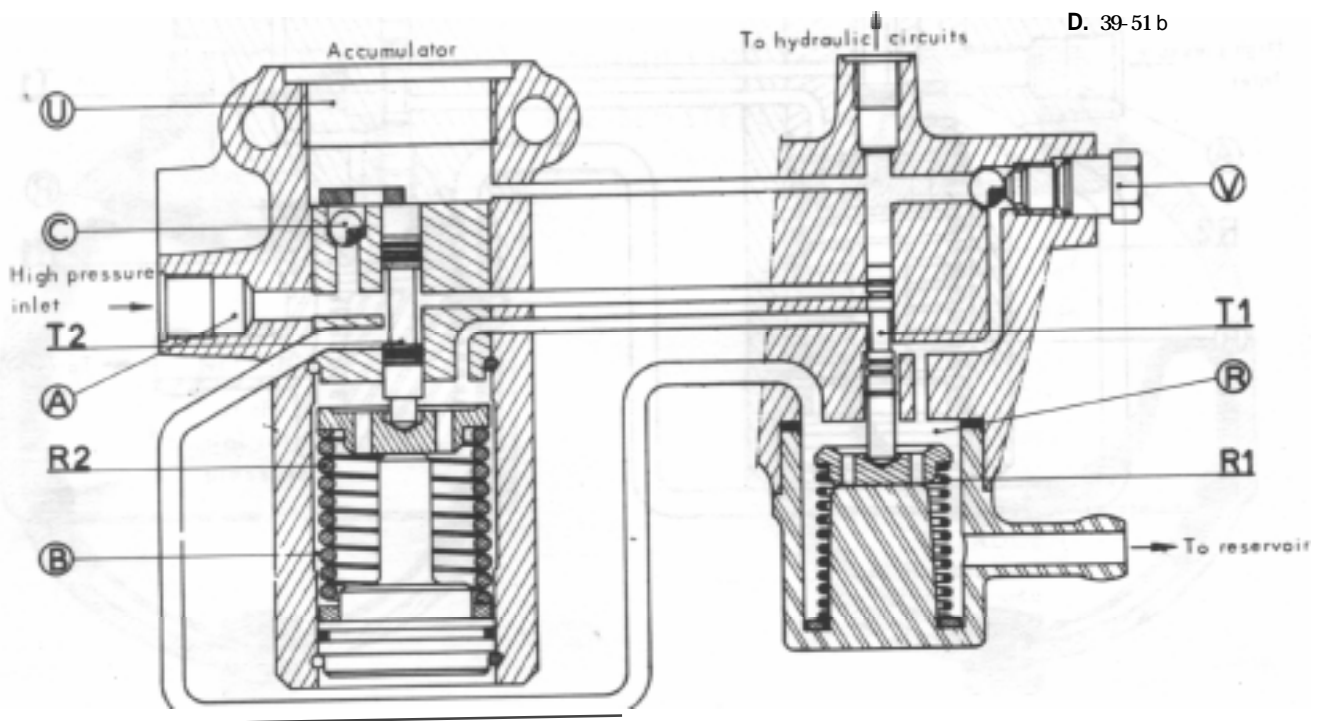

Meanwhile the pressure continues to rise in chamber U and the pilot valve T.1 is forced further down and connects chamber B to the reservoir via chamber R.

When the pressure in chamber B drops to nil, the slide valve T.2, now subjected to the pressure in chamber U, moves down and compresses the spring R.2. This slide valve connects the feed from the HP pump (chamber A) to the chamber R and to the return to the reservoir.

The pressure existing in chamber U closes the non-return valve C.

The pump circulates fluid back to the reservoir without

c) **Cut-in**

The use of fluid leads to a drop in pressure in the accumulator and chamber U.

The pilot valve T.1 moves up under the influence of the spring R.1. First it closes the port leading to chamber R, then connects the fluid feed from the pump to chamber B.

At this point, the slide valve T.2, under the influence of spring R.2 moves up and closes the return to the reservoir via chamber R.

The pump circulates fluid under pressure to chamber U.

d) **Operating Pressures :**

Cut-out Pressure : 162 - 175 bars 2305 - 2490 psi

Cut-in Pressure : 140 - 147 bars 1990 - 2090 psi

**CUT-IN**

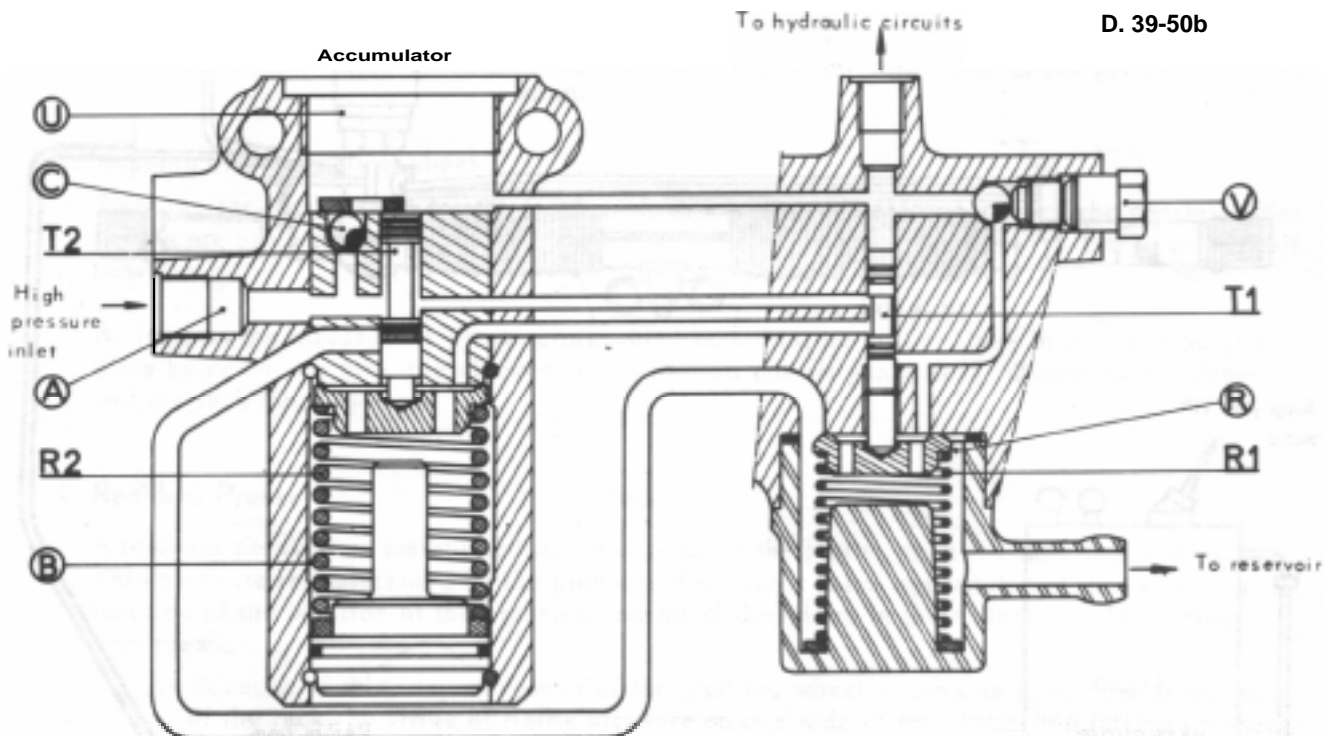

## STEERING

### 1- GENERAL DETAILS

- This is a rack and pinion type operated hydraulically.
- The hydraulic operation allows the use of a very high-geared steering without requiring a great effort on the part of the driver.

### II - CIRCUIT LAYOUT

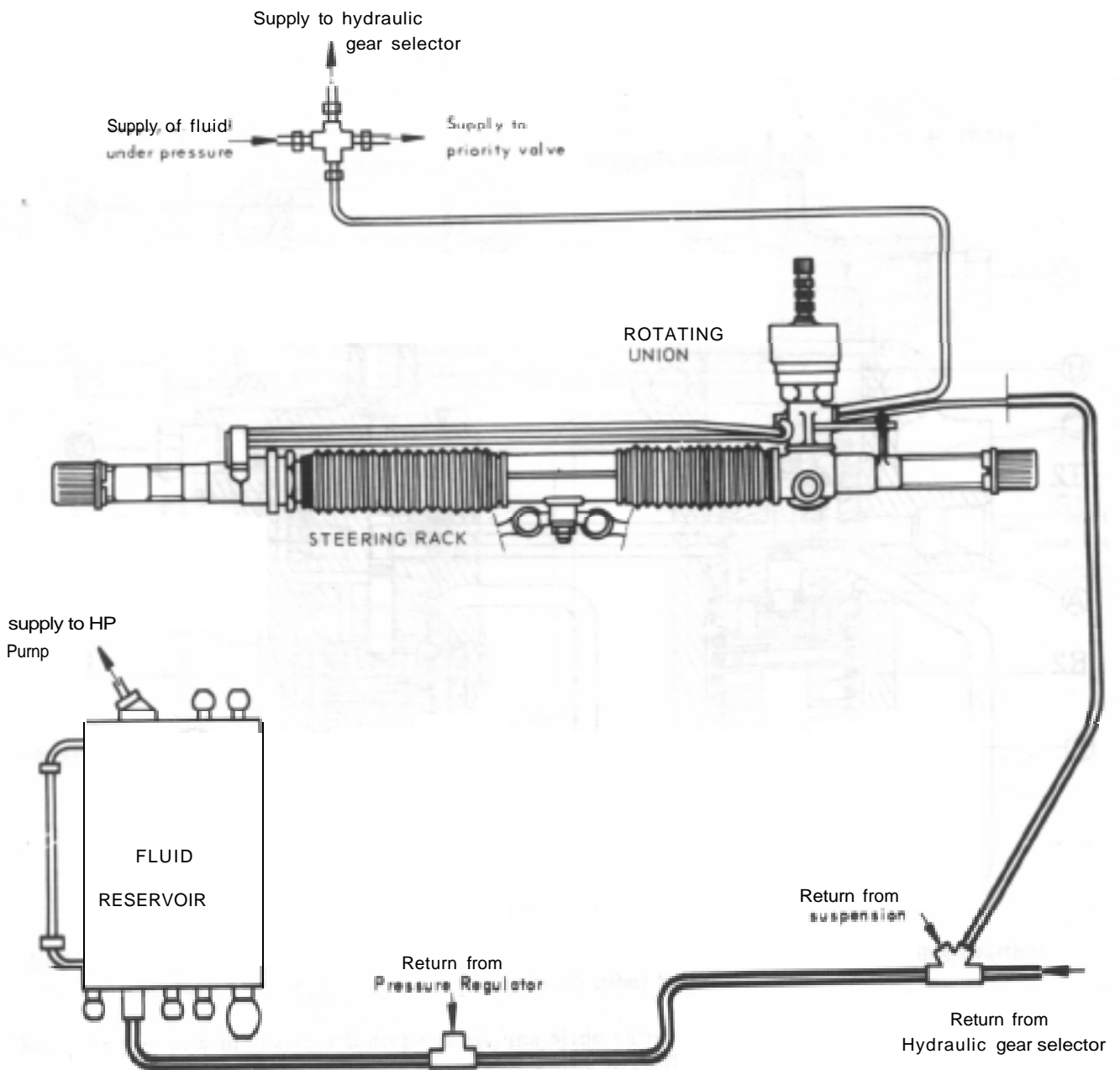

STEERING CIRCUIT

### III - DESCRIPTION

Two main-units comprise the hydraulic part of the steering. These are the piston/cylinder. and the Control Valves with rotating union.

#### 1. Piston/cylinder unit :

This is a double-acting piston connected to the rack.

#### 2. Valves with Rotating Union :

- Two pressure-control slide-valves (one for each side of the piston) are connected to the steering by way of a coupling fork.
- As the slide-valve move with the steering wheel, the hydraulic connections between the fixed (supply of pressure and return) and moving (valve block) parts are maintained by the rotating union.

### IV - OPERATION

#### 1. No movement of the steering wheel :

The fork is at rest and the pressure-control slide-valves are also in equilibrium closing the inlet ports in the valve block.

#### 2. Movement of the Steering Wheel :

When the wheel is turned, this leads to a movement of the slide-valves in relation to their sleeves in the valve block. One slide-valve moves down, the other rises.

The valve slide-valve moves down connects high-pressure to one side of the piston.

The second slide-valve which rises, allows the fluid on the other side of the piston.

#### 3. Stopping of the steering wheel :

When the rack moves it turns the pinion, which moves the sleeves, in which the control slide-valves are situated, in the direction which would tend to make the valves return to the cut off position.

As long as the driver turns the steering wheel he holds the slide-valves in the open position, but when he ceases to turn, the sleeves return to their cut off position in relation to the slide-valves and the rack stops moving.

#### 4. Residual Pressure :

A residual pressure is maintained on either side of the piston when the steering is at rest. This pressure is maintained by the pressure-distributor valve assembly and its value is a function of the position of the pressure-control slide-valves in their sleeves ( The Cross-over pressure ).

- Because of this, any movement of the steering wheel causes an immediate response of the rack, by virtue of rising pressure on one side of the piston and falling pressure on the other side. The movement of rack is thus immediate.

NOTE : A dash-pot is situated under each slide-valve.

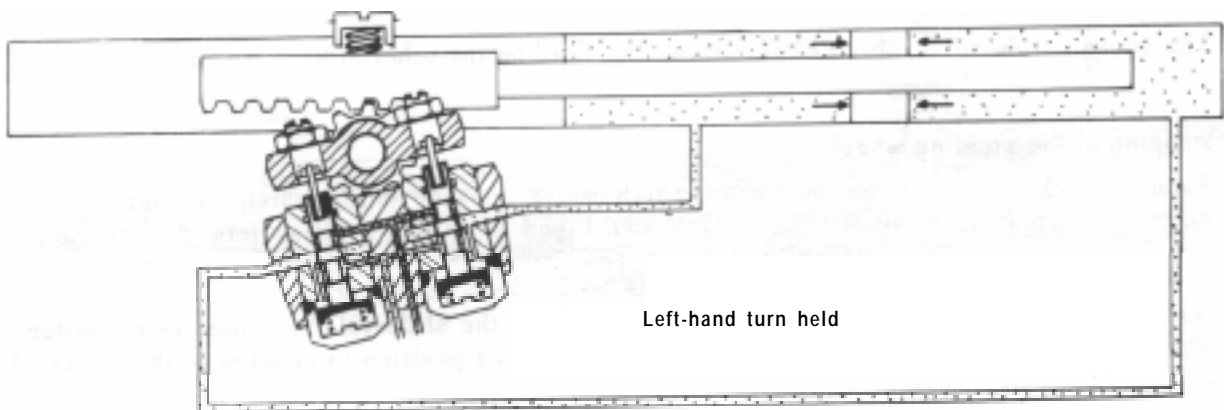
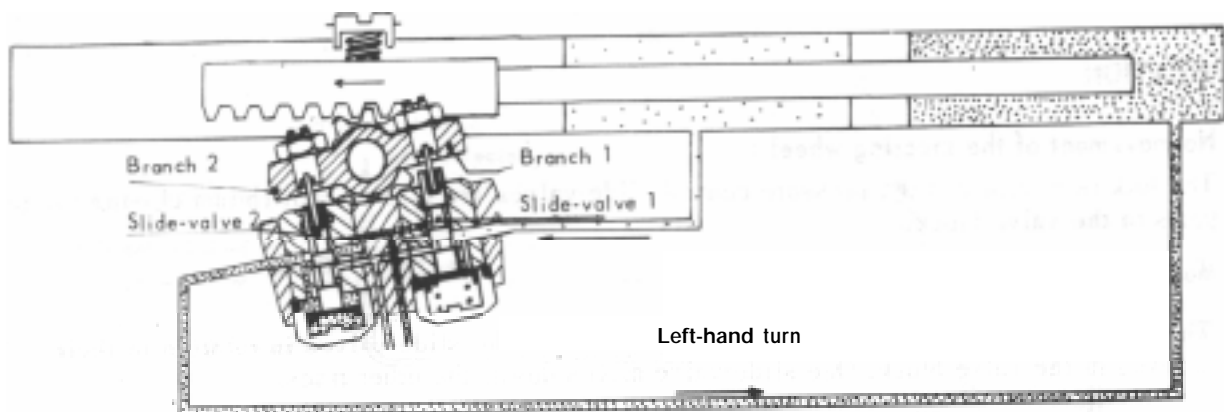
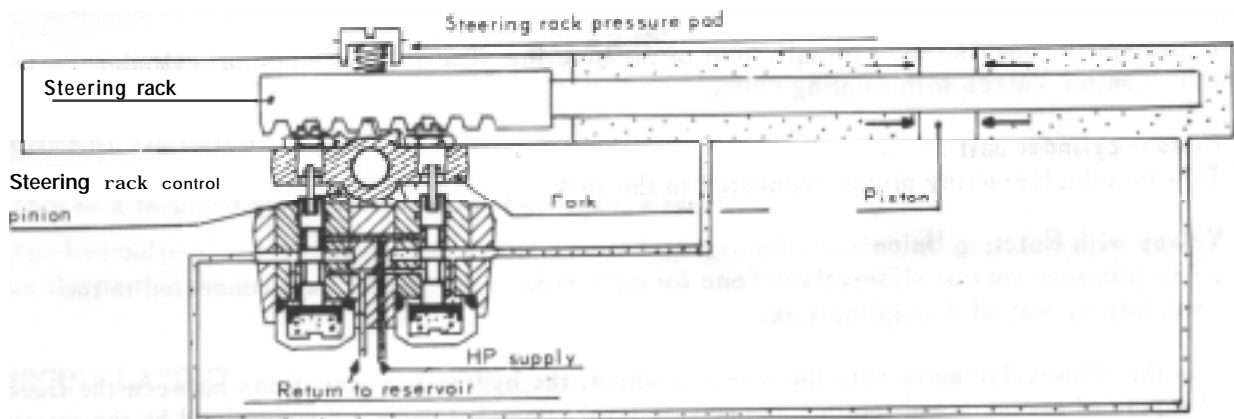

## 5. Mechanical Linkage :

▮ **Steering without Pressure** : To provide a mechanical linkage, the fork has two pegs which operate the pinion direct.

These pegs have some play in their housing; this play allows :

▮ under pressure, the movement of the slide-valve before the pinion

- without pressure, movement of the pinion before the slide-valves reach the end of their travel in the sleeves.

- **Steering under pressure** The play is not felt; the residual pressure which acts equally on both slide-valves keeps them in contact with the fork.

# SUSPENSION

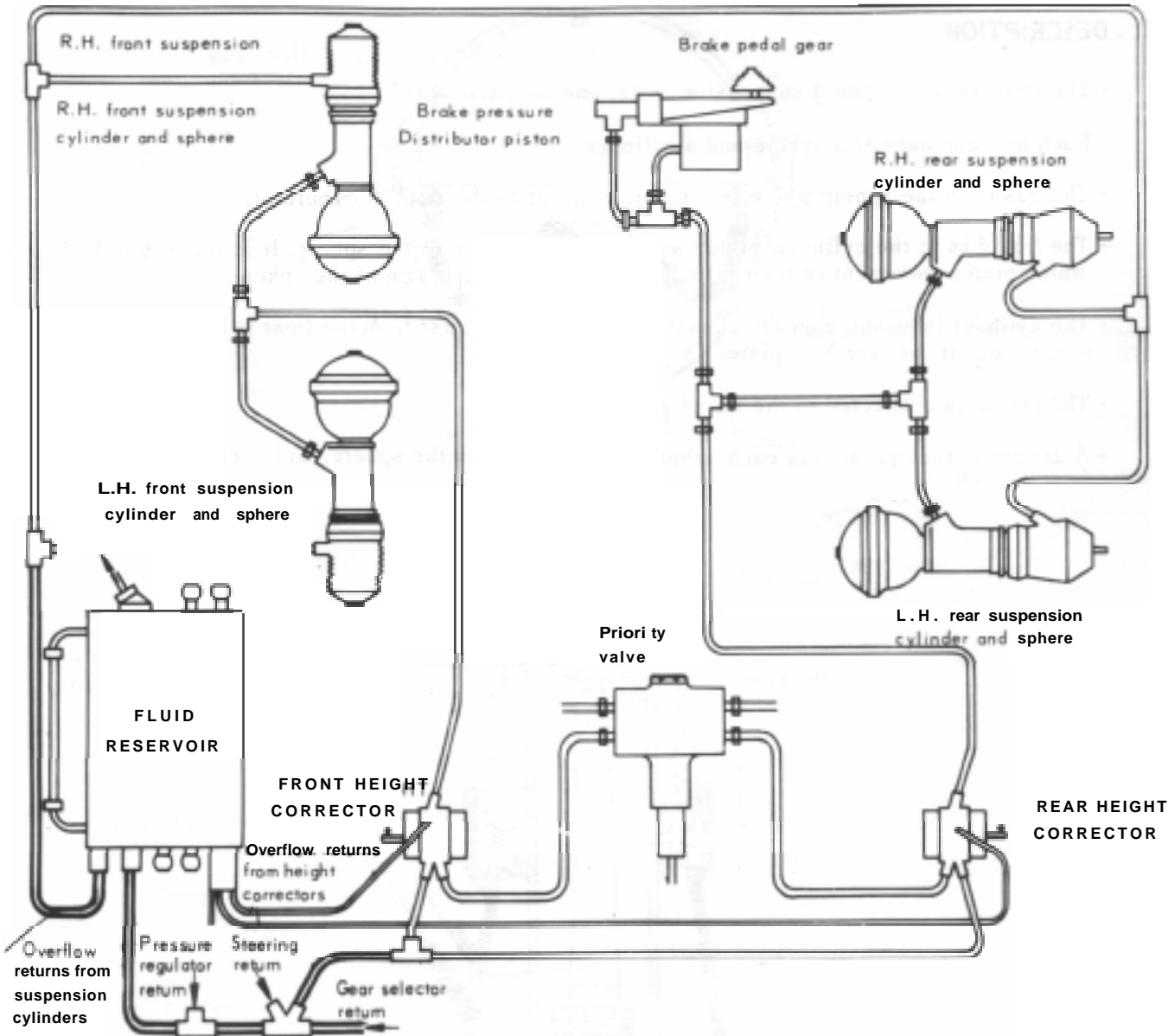



## I: GENERAL DETAILS

Two fluids permit the functioning of the hydropneumatic suspension : a liquid and a gas.

- The gas constitutes the springing medium.
- The liquid provides a means of connecting the unsprung items of the vehicle to the springing medium.

## II - DESCRIPTION

- The chassis rests upon 4 suspension units, one for each wheel.
- Each unit consists of a sphere and a cylinder
- The gas is in the sphere which is similar in layout to the main accumulator.
- The liquid is in the cylinder/piston assembly screwed on to the sphere. It is the means by which piston movement is transmitted to the flexible diaphragm of the sphere.
- The cylinder is mounted on the chassis. It is not rigidly fixed. At the front it is located by two screws and at the rear by a plate.
- The piston is connected to the wheel arm by a rod.
- A damper is incorporated in each sphere. It is screwed to the sphere, and separates the sphere from the cylinder.

SUSPENSION UNIT

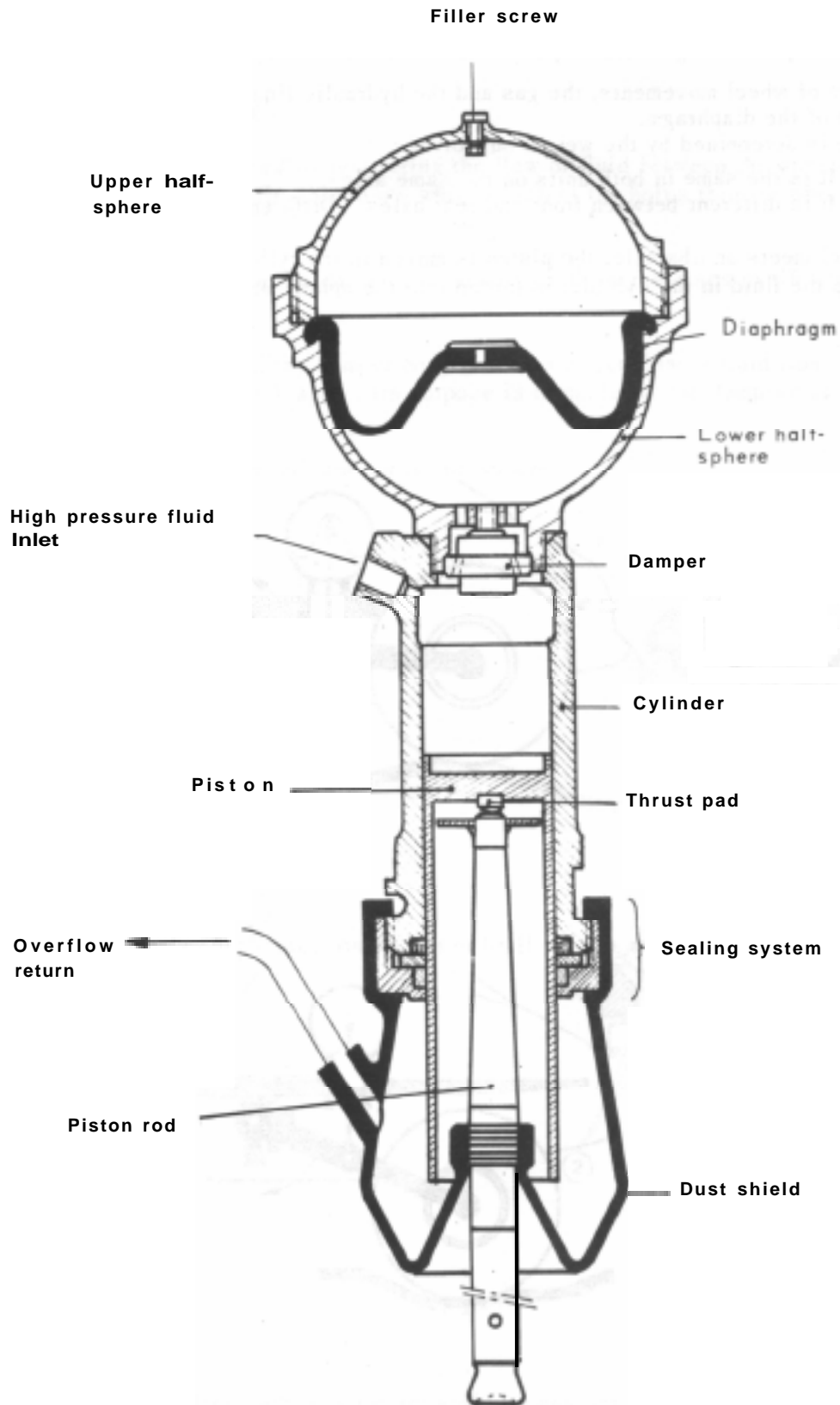

### III - OPERATION

- Since the volume of the spheres is limited by their size, gas without any initial pressure would be insufficient to effectively absorb wheel and chassis movements.
- This condition is satisfied by introducing a large amount of nitrogen. Thus the captive gas is at a pre-determined pressure called the « initial pressure ».
- The initial pressure of the front spheres is different from that of the rears. It is a function of the unladen weight.

NOTE : Too high an initial pressure leads to hammering of the metal cup in the flexible diaphragm on its seat in the sphere (e.g. A front sphere fitted to the rear suspension).

- In the absence of wheel movements, the gas and the hydraulic liquid are at identical pressures on either side of the diaphragm.

This pressure is determined by the weight supported :

- It is the same in both units on the same axle  
It is different between front and rear axles. (Different unladen weight)

- When the wheel meets an obstacle, the piston is moved in its cylinder :  
If it is a bump the fluid in the cylinder is forced into the sphere and the gas is compressed :

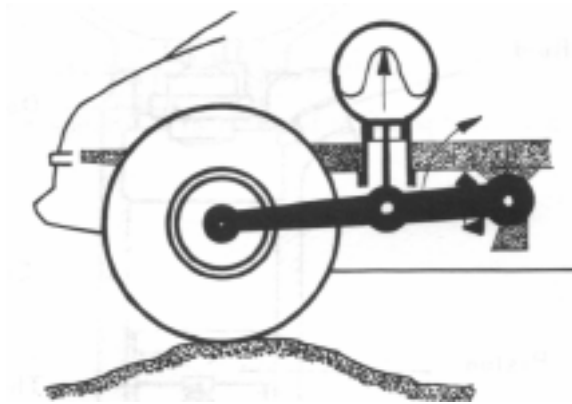

If it is a pothole, the gas expands and the fluid in the sphere enters the cylinder

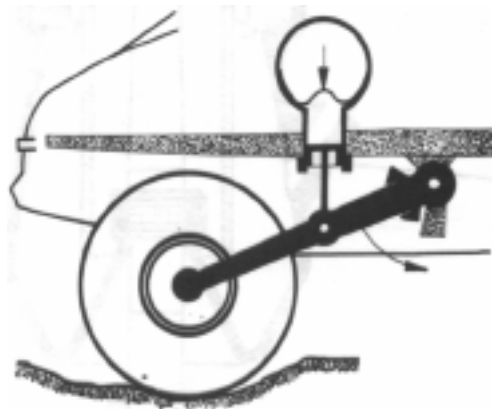

- The compression or expansion of the gas prevents the force of the shock from reaching the chassis.
- After passing the obstacle the pressure re-establishes its equilibrium and the piston its position,

This type of suspension presents definite advantages :

- It enables a simple system of height correction to be used ( Ground clearance is kept constant whatever the load ).
- Thus the flexibility of the suspension is much greater than a chassis spring-type suspension for less bulk. The axles are always in the ideal position between the limit stops.
- The dampers are incorporated in the suspension units.
- There is no maintenance for the whole assembly.

#### IV DAMPERS

The dampers are double-acting :

- The damping action is obtained by restricting the flow of fluid between the sphere and the cylinder, by a system of flexible discs which obstruct the holes through which the fluid passes.
- The inner faces of the nuts of the dampers are domed to allow the discs to lift off the fluid passages.
- The calibrated hole drilled in the damper body allows a direct flow of fluid from the cylinder to the sphere and back again. Its purpose is to minimise the damping at small wheel deflections.
- Since December 1970 the dampers are set in the sphere.

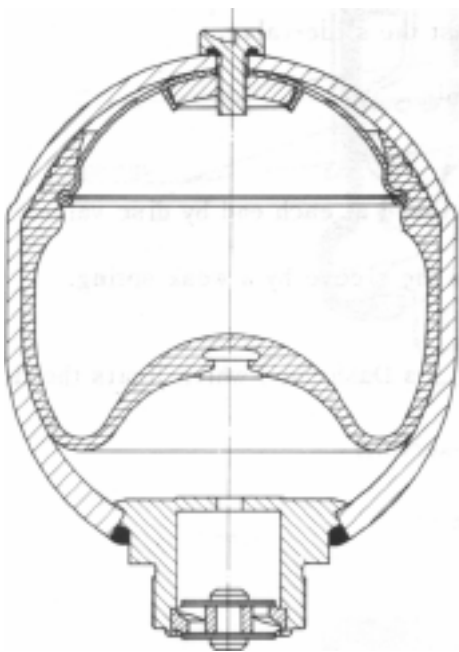

Damper set in the sphere

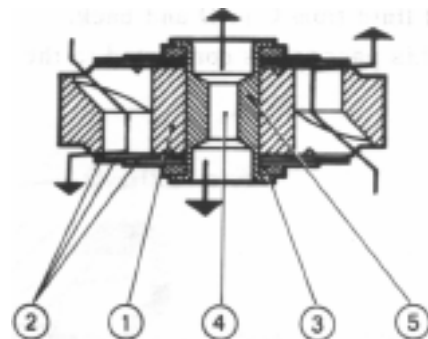

- 1 - Body
- 2 - Disc valves
- 3 - Distance spacer
- 4 - Calibrated by-pass hole
- 5 - Spindle

## V - HEIGHT CORRECTION

- Height correction allows automatic adjustment of and maintenance of a constant ground clearance whatever the static lead.
- This is obtained by the use of two identical correctors ( one per axle ) fed by fluid under pressure
- Each corrector is controlled by a mechanical linkage which is the automatic height control.
- In addition, a manual control can be made to act simultaneously on the two automatic controls.

### 1. The Height Corrector

#### a) Description :

It is a distributor block ( 3-way tap ) which, depending on the position of the slide-valve :

- connects the services ( suspension cylinders ) to the inlet ( HP supply ) .
- connects the services ( suspension cylinders ) to the outlet ( Reservoir )
- isolates both the inlet and outlet from the services ( slide-valve central ) .

The chambers C and D, sealed by rubber diaphragms ( re-inforced by metal cups ) are full of hydraulic fluid which comes from the seepage past the slide-valve.

A seepage return takes the surplus fluid back to the reservoir.

Chambers C and D are interconnected by :

- A clear passage drilled in the sleeve of the slide-valve, closed at each end by disc valves controlled by the movement of the slide-valve.  
In the central position each disc is held against a face on the sleeve by a weak spring.

• A restricted passage inserted in the body of the corrector. ( a Dash-pot which limits the flow of fluid from C to D and back.

This passage is connected to the seepage return to the reservoir.

### HEIGHT CORRECTORS

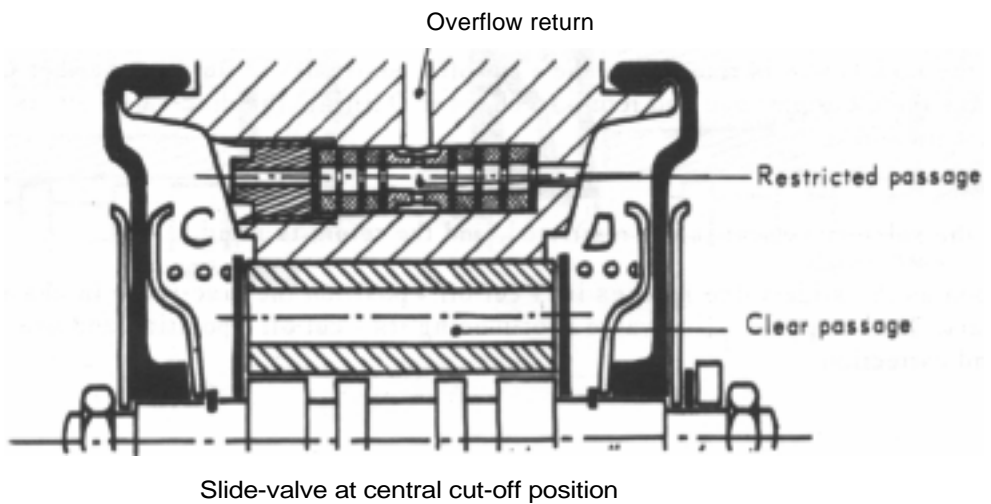
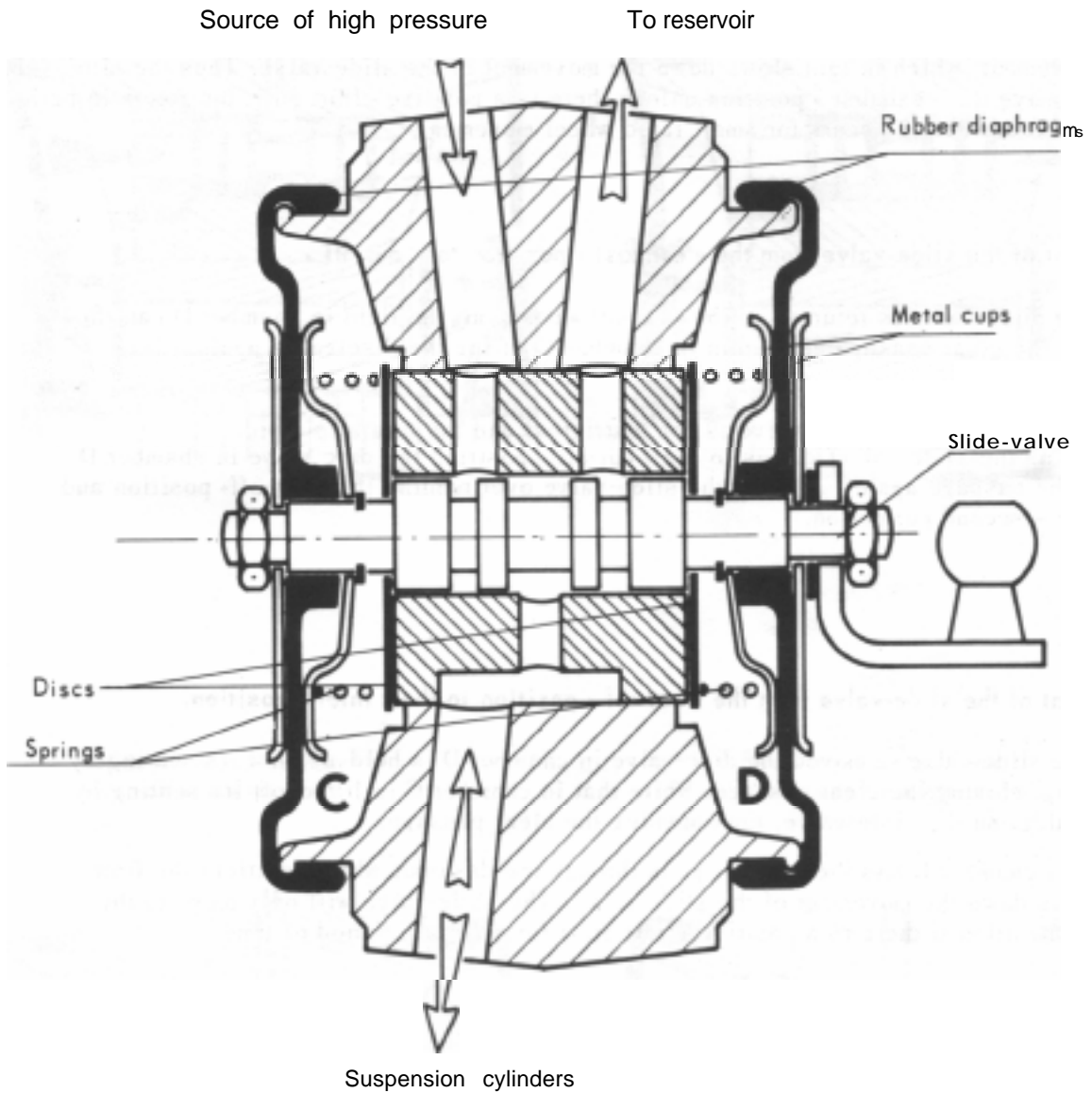

## b). Operation of the height corrector

**- Movement of the slide-valve from the « cut-off » position to the « exhaust » position**

When the slide-valve is moved, that is when it alters its position from « cut-off » the disc valve in chamber C is held on its seating by its return spring, thus closing the clear passage. The disc valve in chamber D is lifted off its seating by the shoulder on the slide-valve, thus opening the free passage.

The fluid in chamber C is therefore obliged to pass through the dash-pot which slows down the fluid movement, which in turn slows down the movement of the slide-valve. Thus the slide-valve will not move the « exhaust » position unless there is a positive effort on it for a certain period of time. No correction occurs for small rapid wheel movements.

**- Movement of the slide-valve from the « exhaust » position to «cut-off ».**

When the slide-valve is returned to the « cut-off » position, the fluid in chamber D can this time use the clear passage and return to chamber C lifting the disc-valve against its return spring.

So the movement of the slide-valve is not restricted, and the return is rapid.

As soon as the slide valve returns to the « cut-off » position the disc valve in chamber D closes the passage again, stopping the slide-valve over running the «cut-off» position and avoiding a second correction.

**- Movement of the slide-valve from the «cut-off » position to the « inlet » position.**

When the slide-valve is moved the disc-valve in chamber D is held against its seating by its spring, closing the clear passage. While that in chamber C is lifted off its seating by the shoulder on the slide-valve, thus opening the clear passage.

Liquid in chamber D has therefore to pass through the dash-pot which restricts the flow and slows down the movement of the slide-valve. The slide-valve will only move to the « inlet » position if there is a positive effort on it for a certain period of time.

**- Movement of the slide-valve from the « inlet » position to «cut-off ».**

When the slide-valve is returned to the « cut-off » position, the fluid in chamber C **can** this time use the clear passage and return to chamber D lifting the disc-valve off its seating against its spring.

Thus the valve-movement is not restricted, and the\_ return is rapid.

As soon as the slide-valve reaches its « cut-off » position the disc-valve in chamber C re-seats. This stops the slide-valve over-running its « cut-off » position and avoids a second correction.

## OPERATION OF THE HEIGHT CORRECTOR ( Diagrams )

Slide-valve moves from  
« cut-off » to « exhaust »

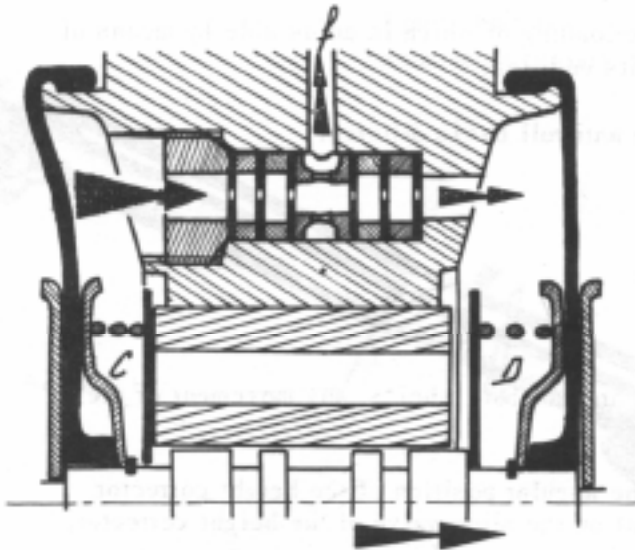

« exhaust » to « cut-off »

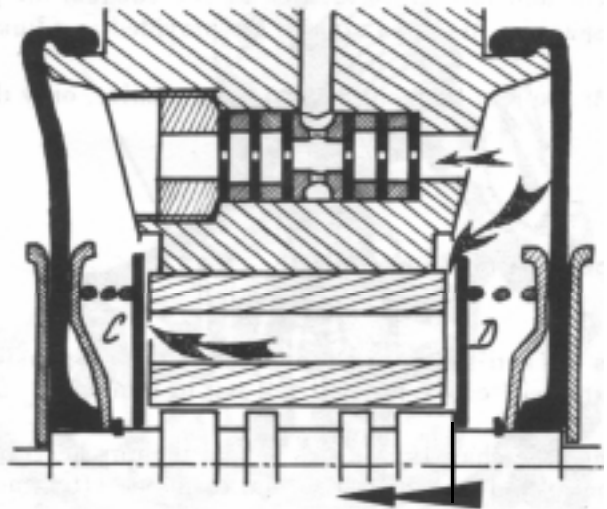

Slide-valve moves from  
« cut-off » to « inlet »

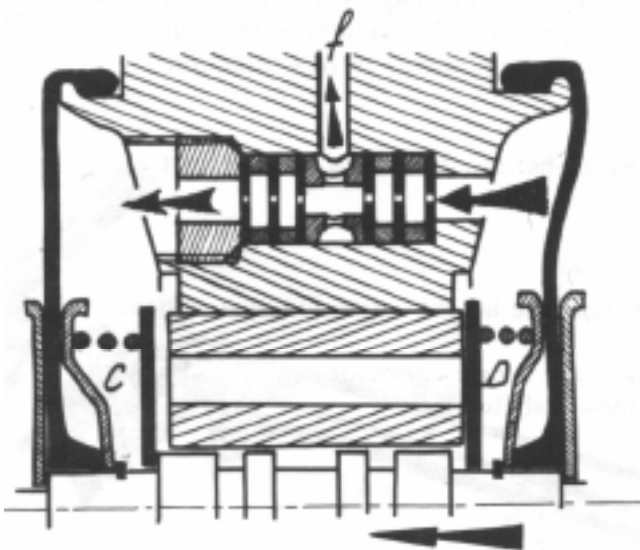

Slide-valve moves from  
« inlet » to « cut-off »

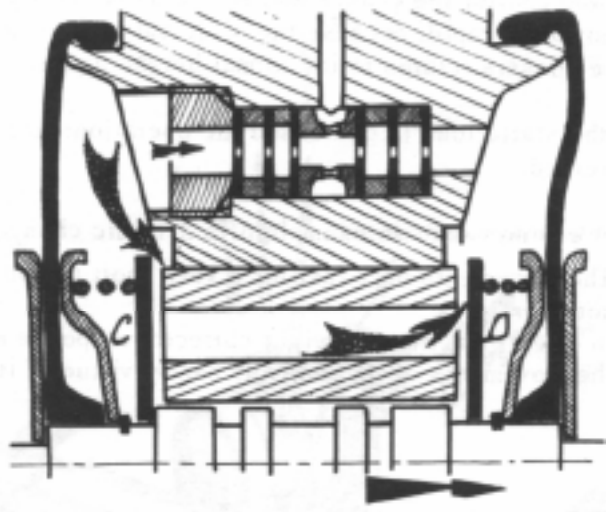



## 2. Automatic height control

Let us examine the front control :

- The ball end on the height corrector slide-valve is acted upon by a << U >> shaped lever brazed on to a torsion control rod. The control rod is clamped to the centre of the anti-roll bar.
- The anti-roll bar is located by two bushes, the pre-loading of which is adjustable by means of spacers. Also two clamps are provided to adjust its end-float.
- At the rear the control system is similar, only the anti-roll bar is different.

### Operation of the controls :

As the anti-roll bar is connected to the suspension arms of both wheels, any movement of the latter will cause the anti-roll bar to rotate.

When the chassis is at its normal running height, the angular position of the height corrector control rod is adjusted so that it has no effect at all on the slide-valve of the height corrector, thus. it remains in its «cut-off» position.

To understand the working of the height correction system, let us take the simple example of a change in the static load.

An increase in the load causes a movement of the chassis and thus a rotation of the anti-roll bar. This movement is transmitted to the height corrector control rod which is therefore twisted, and puts a continuous load on the height corrector control rod.

The slide-valve is therefore pushed in to the « inlet » position.

Now the amount of fluid between the diaphragm and the piston is increased and the chassis rises. This movement reverses the movement of the anti-roll bar. The load imposed on the slide-valve by the control rod ceases and it returns to the « cut-off » position. The return to the <<cut-off » position is rapid, because the slide-valve does not offer any resistance in this direction. The chassis returns to its normal height again.

If the static load is decreased the operations are similar, but the directions of movement are reversed.

Let us now take an example of a dynamic change of load.

- The movements only last for a very short period of time, the height correction system does not operate.  
effect, the time of height corrector response makes the height corrector control rod absorb the movements of the anti-roll bar by virtue of its torsional flexibility.

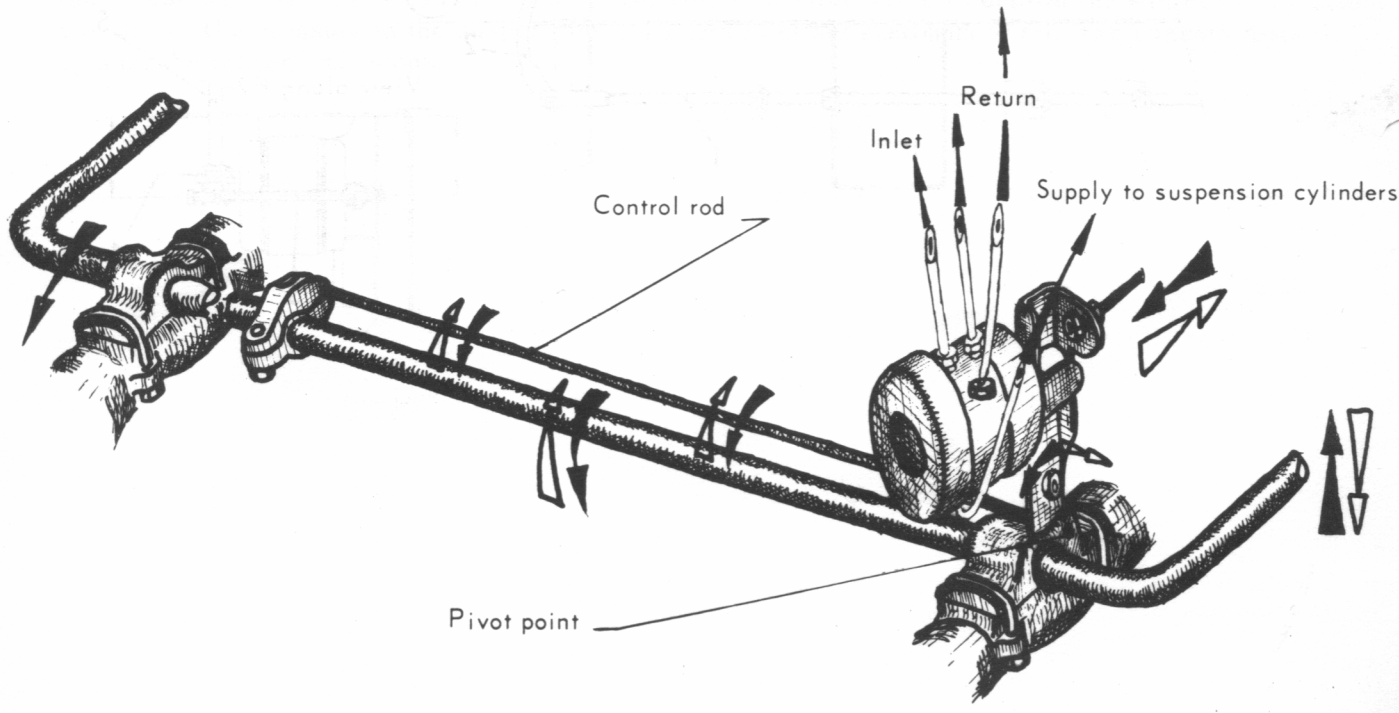
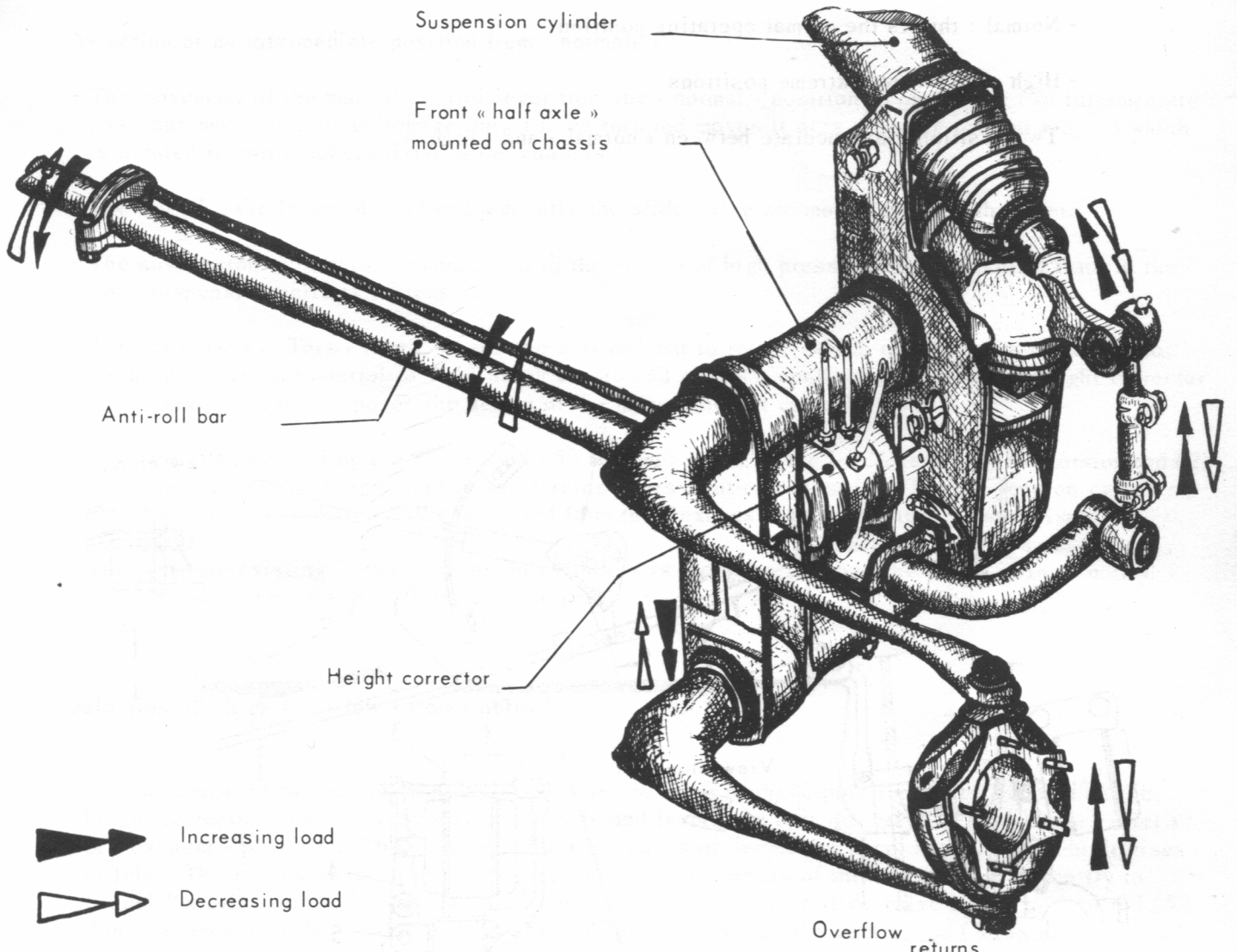

### 3. Manual height control

A manual control is provided to override the normal operation of the slide-valve and allows the driver to select 5 different positions. :

- Normal : this is the normal operating position
- High or low : two extreme positions
- Two positions intermediate between « normal » and « high »

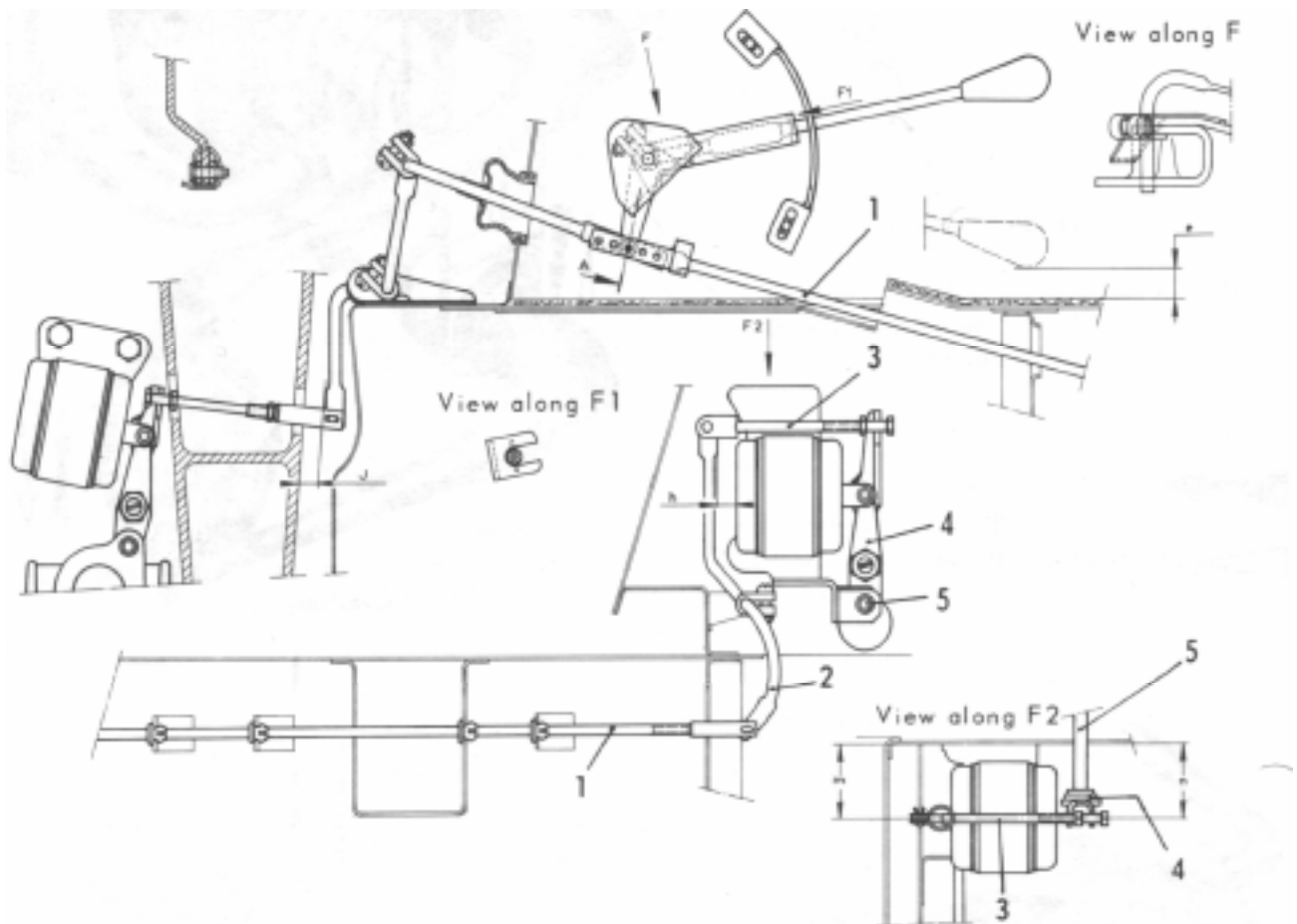

## Operation

The explanation is given showing the front height corrector, but applies equally to the rear.

### **Selection of an intermediate position from « normale ».**

- The movement of the manual control lever from the « normal » position to one of the two intermediate positions moves the front linkage rod (1). As this rod moves it acts upon the torsion rod (2) which is located in two brackets fixed to the chassis.
- The rod (3), the lever (4) and consequently the slide-valve are moved towards the front.
- The suspension cylinders are connected to the source of high pressure. The amount of fluid in the front suspension units is increased.
- The car « rises ». This « rise » causes the anti-roll bar to rotate, which transmits its movement to the height corrector control rod (5) which twists and exerts a continuous pull on the height corrector slide-valve, this pull opposes the action of the manual height control.
- When the load exerted by the control rod (5) becomes equal to the load exerted by the torsion rod (2) the slide-valve is no longer held in and returns to its « cut-off » position. The suspension cylinders are cut-off from the source of pressure and from the « exhaust » position, the car stabilises.
- The pressure existing in the suspension cylinders is the same as when the car is in the « normal » position, only the volume of fluid has changed.

### **Selection of « high » or « low » from « normal »**

- The movement of the manual control lever to one or other of these positions exerts a load on the height corrector slide-valve by way of the rods and levers, so that the valve is held in the « inlet » or « exhaust » positions. The volume of fluid increases or decreases accordingly. The vehicle rises or falls. These movements of the car cause opposite movements of the anti-roll bar which try to cancel the effect of the initial load acting on the height corrector slide-valve by the control rod (5). Equilibrium cannot be established because the load created by the control rod (5) is always less than created by the torsion rod (2). The height corrector slide-valve is held in the « inlet » or « exhaust » positions. The pressure in the suspension cylinders is either maximum or nil. The chassis rests against the rubber limit stops.

## 4. Distribution and isolation of pressure

a) For all D vehicles except DV - DT

-Priority valve

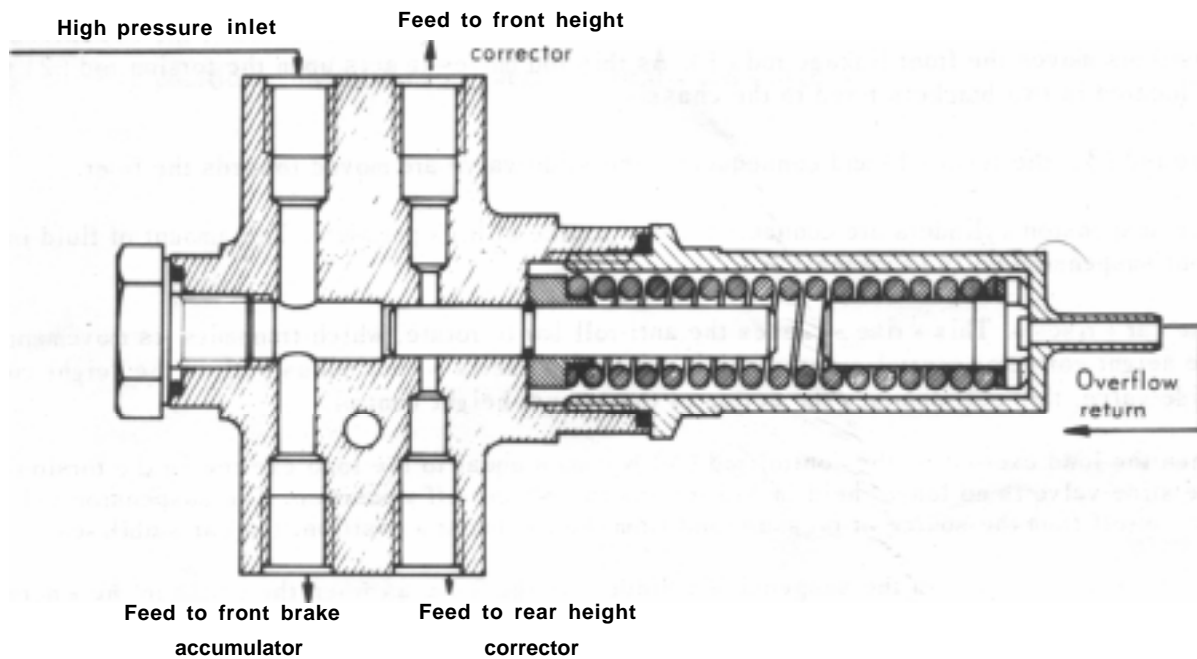

- The priority valve has four ports, two of which ( feeds to front rear height correctors ) are closed by a slide-valve when there is no pressure in the system.
- When pressure is building up in the system priority is given to feeding the front brakes,
- When the pressure is sufficient ( 110 - 130 bars ) to overcome the pressure of the slide-valve return spring, it is moved across and opens the supply to the front and rear height correctors.
- Any seepage between the slide-valve and the body of the priority valve is collected and returned to the reservoir.
- The valve plays a safety role : its slide-valve isolates the suspension circuits from the source of pressure.

b) For DV and DT vehicles

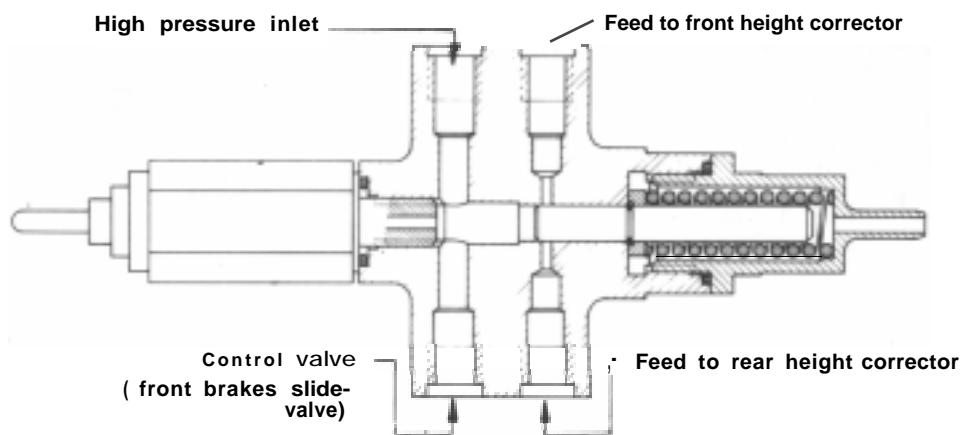

- As soon as the pressure builds up in the circuit, priority is given to feeding the front brakes. When the pressure is sufficient 1015 to 1305 psi ( 70 - 90 bars ) to overcome the pressure of the slide-valve return spring, the latter opens the ports to the front and rear height correctors. The control valve plays a safety role : it eventually isolates suspension circuits from the source of pressure.

- When the driver releases the brakes :

The pressure-control slide-valve for the front brakes, under the influence of its return spring R1, and the pressure p in chamber C1 takes up its normal « at rest » position. The pressure p drops.

The slide-valve for the rear brakes, under the influence of its return spring R2 and the pressure p' in the chamber C2, returns to its normal «at rest » position. The pressure drops.

2. Preponderance of front braking : Pressure rises in the front brake circuit first.

When this pressure is sufficient to compress the spring R2 the rear brakes are fed.

This distribution of braking pressure is independant of the load in the car. The difference is maintained no matter what the pressure is on the pedal.

3. Reserve of pressure : The main accumulator is also the brake accumulator. Because of this its initial inflation pressure is lower ( 60 bars (864 psi ) instead of 65 bars (949 psi )) than a normal main accumulator. This allows a larger reserve of fluid under pressure for the brakes.

The pressure warning light operates on the pressure in the main accumulator.

It lights the warning lamp on the dashboard when the pressure is between 75 to 95 bars (1080-1368 psi)

4. Operating units :

- At the front the brake pistons are 60 mm in diameter
- At the rear the brake pistons in the wheel cylinders are 18 mm in diameter.

## HYDRAULIC CONTROL OF CLUTCH AND GEARCHANGE

### I- GENERAL DETAILS

- To carry out all the operations relative to changing gear and using the clutch, the driver uses only the gear lever and the accelerator pedal. The vehicle has a conventional gearbox and clutch, the clutch and gearchange operations are carried out automatically.
- This automatic control is maintained by two principal units
  - the hydraulic gear selector
  - the centrifugal regulator

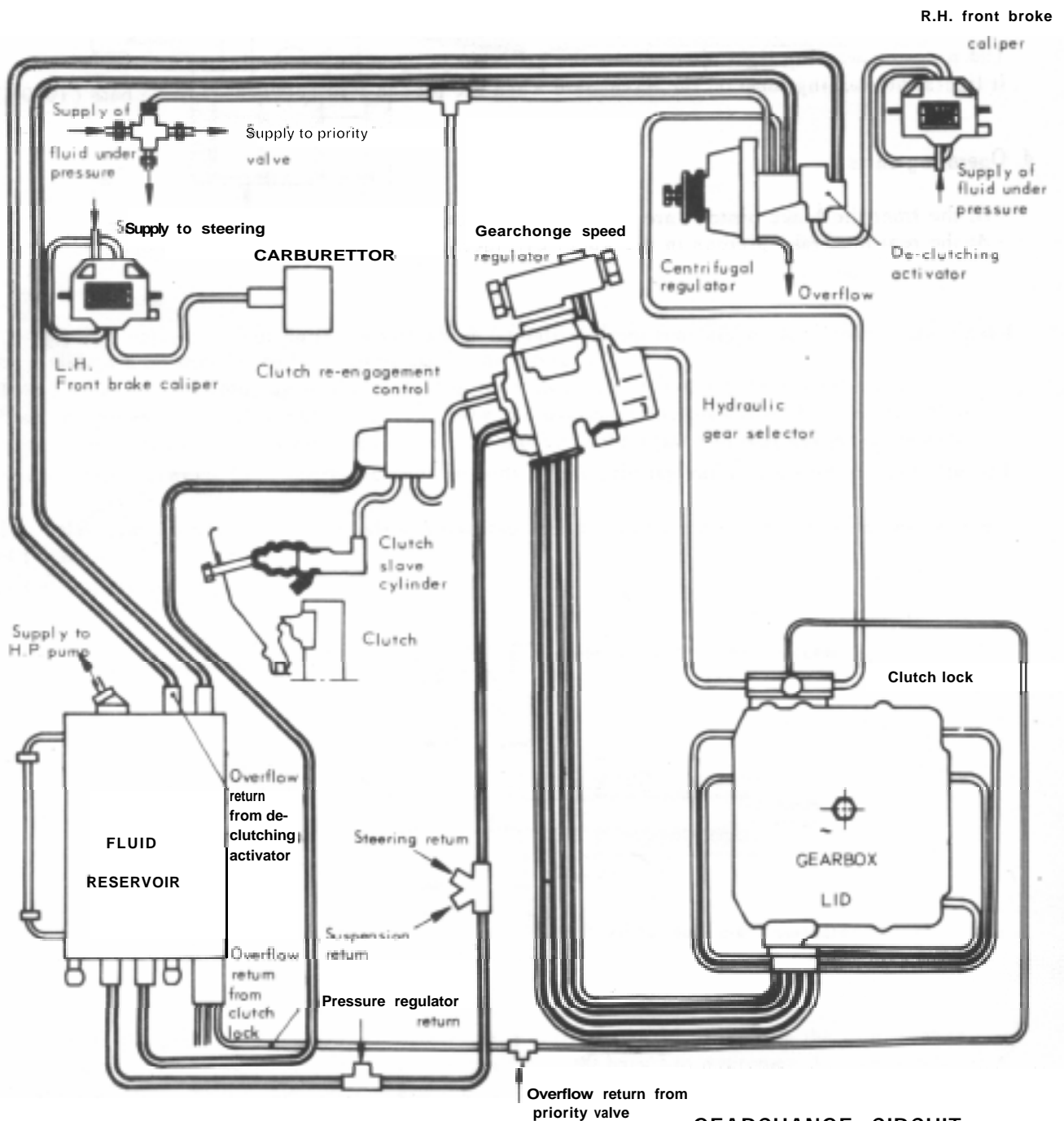

GEARCHANGE CIRCUIT

## II - THE HYDRAULIC GEAR SELECTOR

### 1. Purpose :

- The hydraulic gear selector ensures de-clutching in neutral, and from neutral allows the engagement of any gear.
  - During the gearchange cycle, it controls in the following order :
    - de-clutching,
    - dis-engagement of the gear in mesh,
    - engagement of the gear selected,
    - re-engagement of the clutch.

### 2. Description :

- The various elements of the hydraulic gear selector are :
  - a) the selector slide-valve :**
    - This is hollow and has 1 inlet port for HP-fluid and 5 outlet ports ( one for each gear ).
    - Longitudinal and circumferential grooves are machined in the slide-valve to allow the return of fluid to the reservoir by way of the front face of the gear selector. ( From a gear, for example ).
    - In neutral the outlet ports in the slide-valve are opposite a plain part of the sleeve in which it operates. Sealing is maintained only by the accuracy of the machining of the slide-valve and its sleeve (A tolerance of a few microns).
    - The positioning of the slide-valve in its sleeve is very important, and is the object of a very precise setting which corresponds to a given position of the gear lever.

#### **b) The automatic clutch control pistons :**

- Five in number ( 1 for each gear ), are able to move upwards in the gear selector when they are pressurised. They return to their initial position by means of the return spring of the automatic clutch control slide-valve.

#### **c) The automatic clutch control slide-valve :**

#### **d) The synchro-delay pistons :**

Four in number, only three of which can move, the fourth being a plug. They are returned to their initial position by two return springs.

- There is no synchro-delay piston for 1st gear, although it is synchronised.



e) The manual clutch control slide-valve :

Controlled manually by a lever and a rod, and has only two positions.

- normal driving position ( Slide-valve in )
- de-clutched position ( Slide-valve out ).

At its lower end are two drillings at right-angles to each other (As shown in diagram ).

f) Internal passages :

The five outlets to the gearbox pistons, shown on the diagram by numbered rings, are connected to the automatic clutch control pistons.

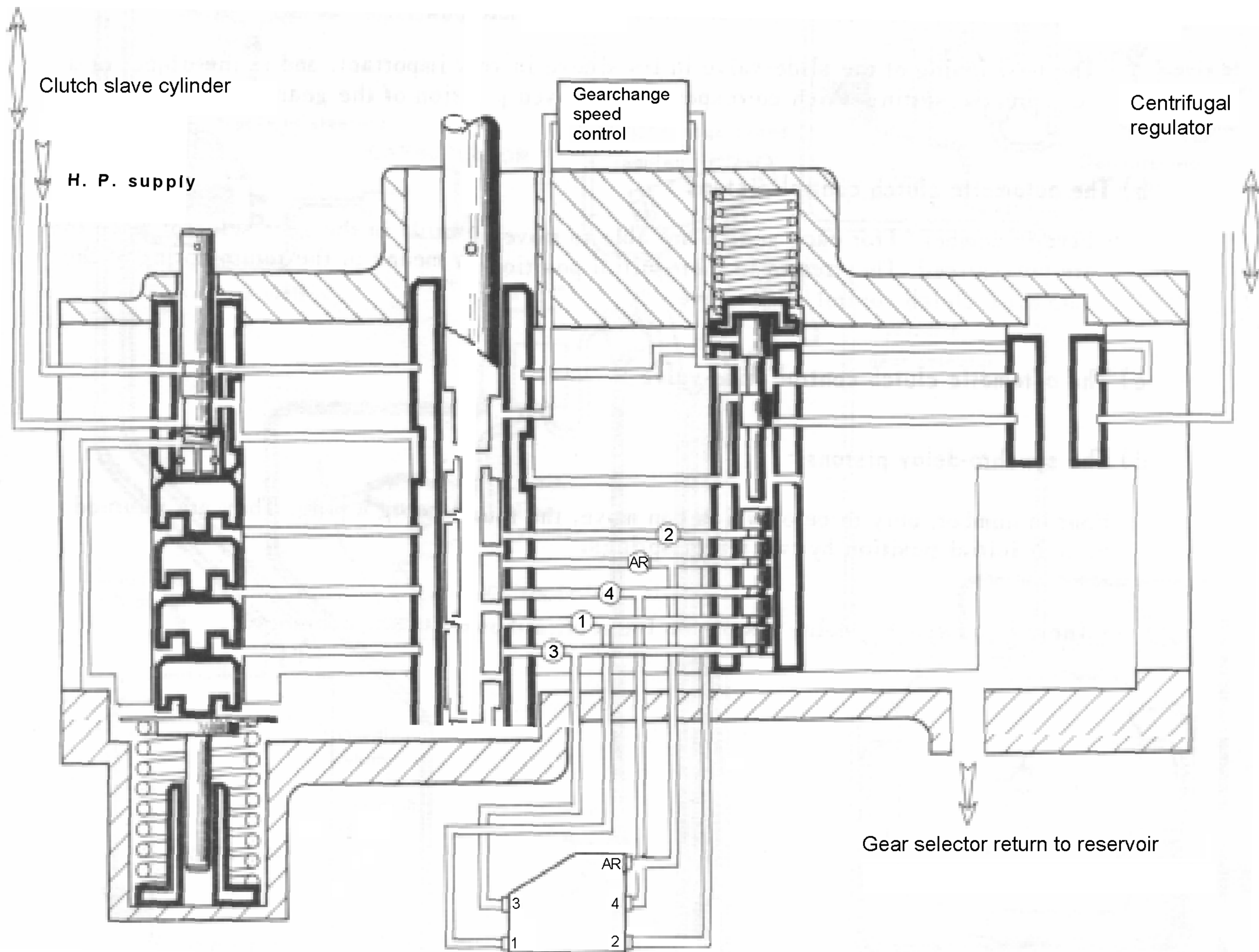

### 3. Operation :

#### a) Manual clutch control :

- The slide-valve in its normal position : fluid under high pressure is supplied to the hydraulic gear selector.
- The slide-valve in its withdrawn position : in this position the slide-valve :
  - cuts off the supply of HP fluid to the clutch and gearchange circuit
  - allows the fluid in the clutch slave cylinder to escape to the reservoir.
- In the latter position of the slide-valve, the vehicles clutch is engaged, which allows :
  - the freeing-off of the motor and starting on the handle
  - valve clearance adjustments, etc....

#### b) Rise of pressure - de-clutching :( manual clutch control slide-valve in its normal position )

- Before the hydraulic selector slide-valve is supplied with fluid under pressure, the position of the automatic clutch control slide-valve is such that :
  - the supply to the selector slide-valve is cut off
  - the port to the clutch slave cylinder is open.
- When HP arrives the slide-valve operates as a pressure control valve and de-clutching occurs at a pressure of 50 - 70 bars ( 725 to 1000 psi ). ( This pressure is the result of the calibration of the spring above the slide-valve ).
- In its regulating position the slide-valve allows fluid to pass to the selector slide-valve, (via the gearchange speed control ).
- Therefore, with the engine idling, in neutral, the clutch is out.

#### c) Engagement of 1st or reverse gear :

- By moving the lever the selector slide-valve is aligned in such a way that the line to the chosen gear is pressurised. The pressure rises simultaneously :
  - in the gear circuit ( gear selector fork shaft pistons ),
  - in the automatic clutch control pistons.
- The surface area of the pistons and the strength of the springs are such that the pressure causes..
  - Immediate movement of the gear selector fork shaft until the gear is engaged.
  - Then, as the pressure continues to rise, the movement of the automatic clutch control piston.

d ) Engagement of 2nd, 3rd, or 4th gears :

When the chosen gear circuit is connected to the supply of pressure ( by the selector slide-valve ) the pressure rises simultaneously :

- in the gear circuit ( gear selector fork shaft pistons )
- in the automatic clutch control piston circuit
- in the synchro-delay piston circuit

For the aforementioned reasons, the different phases of operation **occur** in the following order :

- Movement of the selector fork shaft until synchro cones begin to contact
- Movement of the synchro-delay piston : which allows the volume of fluid to increase and the pressure to stabilise ( while synchronisation continues at a constant pressure ).
- Rapid movement of the selector fork shaft allowing full engagement of the gear once the synchro piston has bottomed.
- Movement of the appropriate automatic clutch control piston.

e) Re-engagement of the clutch :

- Whatever gear is selected, the final operation of the gear selector is the movement of the automatic clutch control piston.

As it moves, the piston causes the automatic clutch control slide-valve to rise.

The equilibrium of the pressure balance is upset, and in its new position the slide-valve allows :

- Fluid to pass to the selector slide-valve ( This pressure holds the gear in engagement ).
- The connection of the clutch slave cylinder to the centrifugal regulator. ( We shall see that clutch dis-engagement and re-engagement can take place when the centrifugal regulator allows the fluid in the slave cylinder to escape back to the reservoir ).

f ) Return to neutral :

Between each gear the selector slide-valve connects all the circuits under pressure to return to reservoir via the grooves it carries. All the parts return to their initial positions under the action of their return springs.



### III - THE CENTRIFUGAL REGULATOR :

#### 1. Purpose :

- The centrifugal regulator controls the clutch engagement when moving off and its dis-engagement when the vehicle stops with a gear still engaged. Its operation is in relation to engine speed.

#### 2. Description :

It comprises three major parts :

- A classic type-centrifugal governor
- A pressure control slide-valve and sleeve assembly
- A de-clutching activator fed by pressure from the front brakes

#### 3. Operation

##### a) Centrifugal governor :

This transmits by way of a pressure pad, to the control slide-valve, a force which varies with engine speed.

With the engine stopped, this force corresponds to the calibration of the springs.

When turned the weights fly outwards, compressing the springs until there is a state of balance between the centrifugal force and the spring pressure.

The force  $F$  transmitted to the slide-valve by the pressure pad becomes progressively less as the engine speed rises.

##### b) Pressure-control slide-valve assembly :

- The slide-valve and its sleeve act as a pressure-control device
  - Equilibrium of the slide-valve is achieved when the forces acting on its end (pressure and spring ) are equal to the force exerted by the pressure pad

$$p \times s + R = F$$

- The operating pressure ( regulated pressure ) is thus solely a function of the force  $F$ , namely the engine speed.

$$p = \frac{F - R}{s}$$

Thus the regulated pressure diminishes when the engine speed is increased and vice-versa.

NOTE : When the clutch is engaged, the slide-valve's position connects the clutch circuit to the return system.

Therefore, during gearchanges, only the automatic clutch control slide-valve controls de-clutching and engagement.

- A dash-pot is provided to damp sudden pressure rises and the movement of the control valve.

### c) De-clutching activator :

- **Purpose** : The activator facilitates the dis-engagement of the engine from the gearbox during a rapid stop with the brakes applied and a gear engaged. Complete de-clutching is obtained by increasing the pressure in the clutch circuit by about 10 bars ( 145 psi ).
- **Operation** :
  - When decelerating, the pressure in the brakes also acts on the de-clutching activator piston, compressing its return spring.
  - As it is moved back, the piston effectively reduces the strength of the spring R at the end of the slide-valve.
  - For a given engine speed, the slide-valve's equilibrium is obtained with a higher pressure

$$\text{previously } p = \frac{F - R}{s}$$

R becomes less, R remains constant, so p increases ( by 10 bars, approx 145 psi ).

### d) Adjustment of the clutch engagement speed :

Let p be the pressure corresponding to clutch drag at a given engine speed.

- By screwing in the adjustor screw, F increases, p increases\_ The pressure corresponding to the clutch drag will be obtained at higher engine revolutions.
- By unscrewing : the reverse occurs.

### CENTRIFUGAL REGULATOR

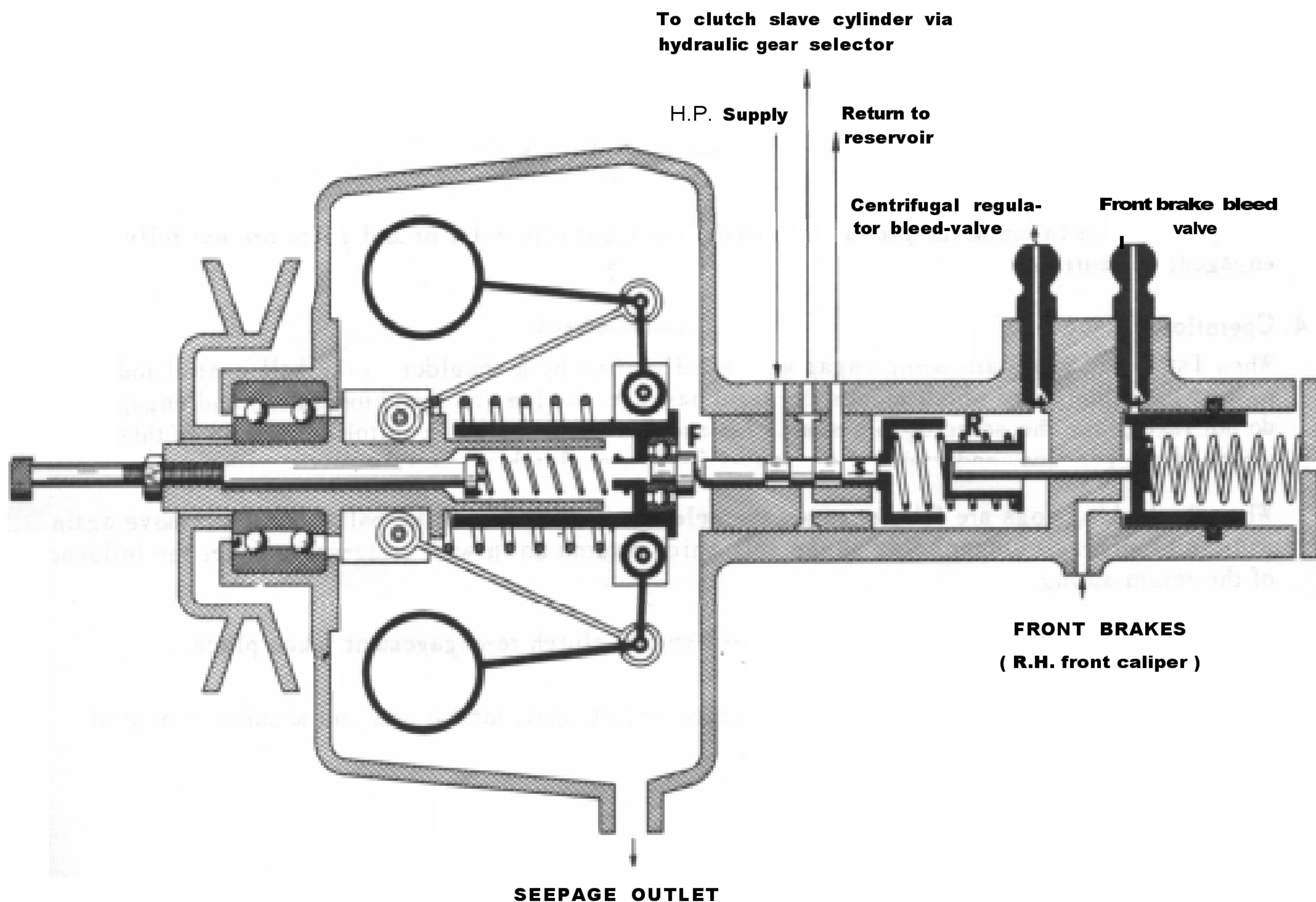

## IV - CLUTCH LOCK :

### 1. Purpose :

This unit is present to stop the clutch re-engaging during changes to and from 1st and 2nd gears, if one or other of the gears is not fully engaged. This safety measure is mainly justified on the re-engagement in 1st gear; due to the absence of a 1st gear synchro delay piston in the hydraulic selector, the latter could allow re-engagement before the synchro and locking dogs have had time to operate.

### 3. Description :

The clutch lock is fitted to the right hand front side of the gearbox, in the hydraulic circuit between the gear selector and the centrifugal regulator.

Thus it cannot hinder de-clutching during gearchanges even if it is closed.

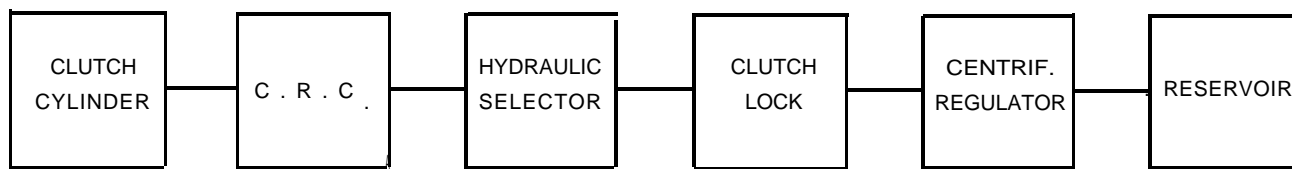

It comprises :

- 1 body
- 1 slide-valve sleeve
- 1 slide-valve with a central groove
- 1 return spring for the slide-valve
- 1 ball control rod and ball

This ball control rod is connected to the selector fork shaft for 1st and 2nd gears by a lever and spring.

### 3. Principle :

The principle is to block the pressure-release circuits if either 1st or 2nd gears are not fully engaged; or neutral.

### 4. Operation :

When 1st or 2nd gears are being engaged, the ball, lifted by a shoulder on the ball control rod, pushes the slide-valve which blocks the fluid passage. As long as synchronisation and engagement do not take place the selector fork shaft ( 1st and 2nd ) and the ball control rod remain in this intermediate position, and stop the escape of fluid from the clutch slave cylinder.

When the locking dogs are fully engaged the selector fork shaft and the ball control rod move again and the shoulder no longer holds up the ball which returns down with slide-valve under the influence of the return spring.

Fluid may now pass the groove in the slide-valve and clutch re-engagement takes place.

For the of 3rd or 4th gears the selector fork shaft for 1st and 2nd remains in neutral and the clutch lock stays open all the time.

## CLUTCH LOCK

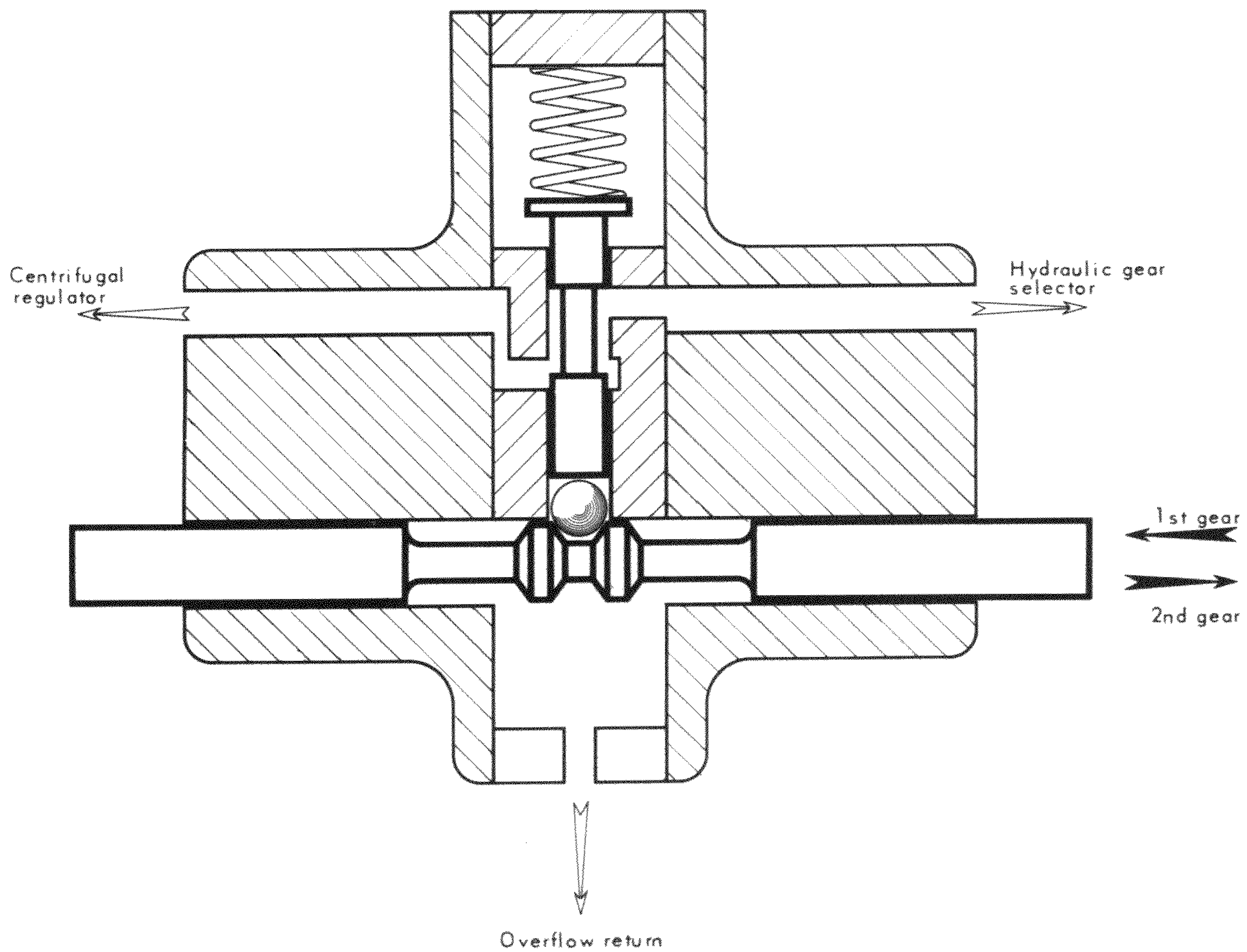



## V - CLUTCH RE-ENGAGEMENT CONTROL ( C.R.C. )

### 1. Purpose :

This unit is present to ensure rapid and progressive re-engagement.

It must :

- Vary the speed of clutch re-engagement according to the position of the throttle
- Allow rapid dis-engagement of the clutch

### 2. Description :

In the hydraulic circuit the CRC is situated between the gear selector and the clutch slave cylinder.

A cam, connected to the primary throttle butterfly spindle by a « Flector » acts, via a roller, on a lever which tensions a spring which in turn permanently applies pressure to a slide valve.

Another « By-pass » slide-valve is pushed towards the first by a weak spring. In the centre of this slide-valve the diameter is smaller than the bore in which it operates.

### 3. Principle and Operation :

#### a) De-clutching :

Principle :

It is necessary for this operation to be as quick as possible. Therefore the CRC must not obstruct the flow of fluid from the gear selector to the clutch slave cylinder at all.

Operation :

Let us start from the position where the clutch is fully engaged. Pressure from the gear selector when de-clutching first moves the by-pass slide-valve back because its return spring is weak. The by-pass valve opens a port which allows free passage to the fluid going towards the clutch slave-cylinder ( Inset I ).

As the pressure rises, the second slide-valve is moved in turn opening a second port and stretching the spring in the CRC. The movement of this slide-valve stops when its return lever bottoms. When the pressure reaches its maximum it becomes equal on both sides of the by-pass valve which returns to its original position under the influence of its spring ( Inset II ).

De-clutching is rapid as the fluid is virtually unobstructed.

#### b) Re-engagement :

Principle :

It is necessary to have a rapid first stage of engagement to the point where the clutch begins to drag and a slower second stage to avoid sudden engagement. To achieve this the return of fluid must be free first and slowed down thereafter.

## CLUTCH RE-ENGAGEMENT CONTROL

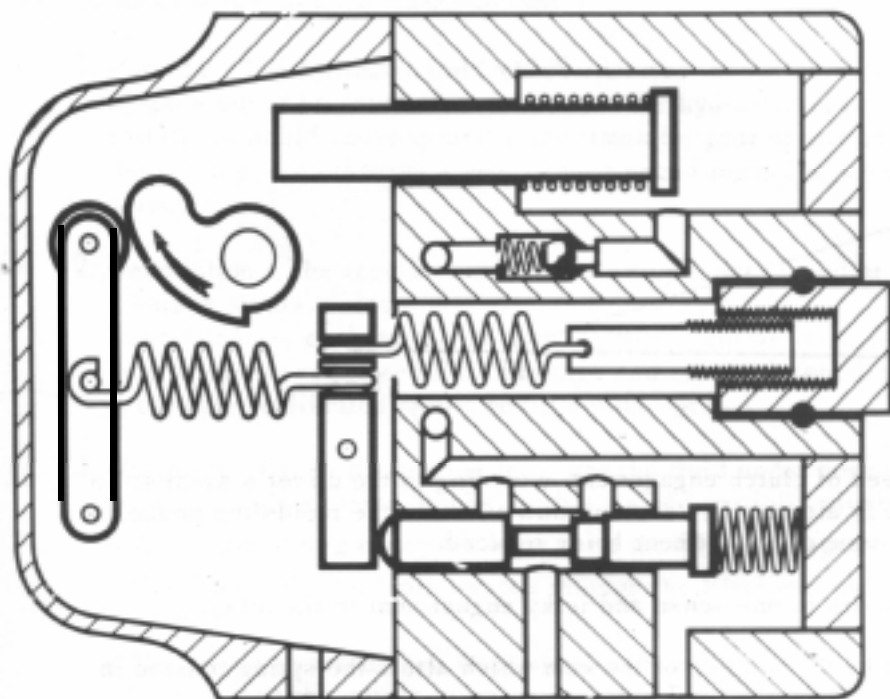

Hydraulic gear  
selector

Clutch sleeve  
cylinder

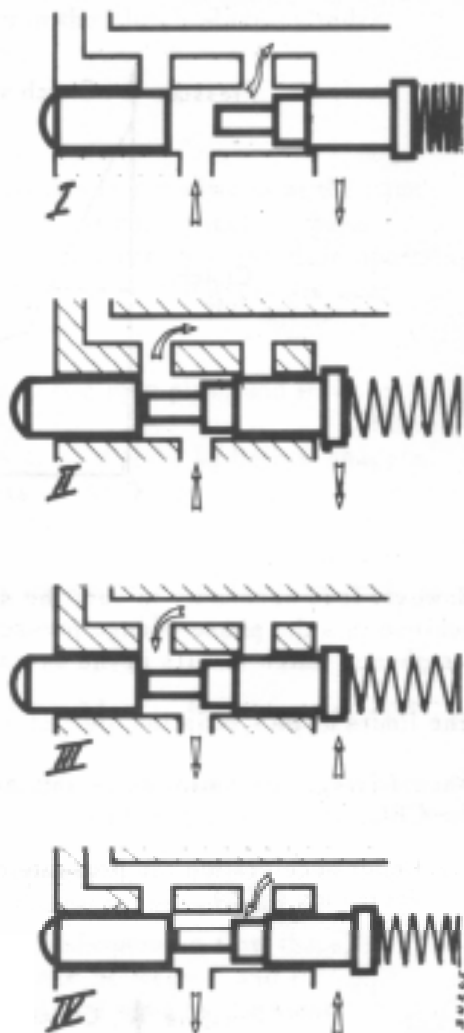

## Operation :

The pipe connected to the hydraulic gear selector is connected to the return to the reservoir by the gear selector.

There is a rapid drop of pressure ( Inset III ), until the slide-valve obstructs the return port; this occurs when the fluid pressure on one side of the slide-valve becomes less than the effect of the spring on the return lever on the other side.

This is the first phase, or rapid phase of re-engagement. In the centre portion of the by-pass valve is the reduced diameter described in the text, this is between the outlet port and the return to gear selector; the pressure continues to drop by way of the outlet, restricted by the by-pass valve, but slowly now,

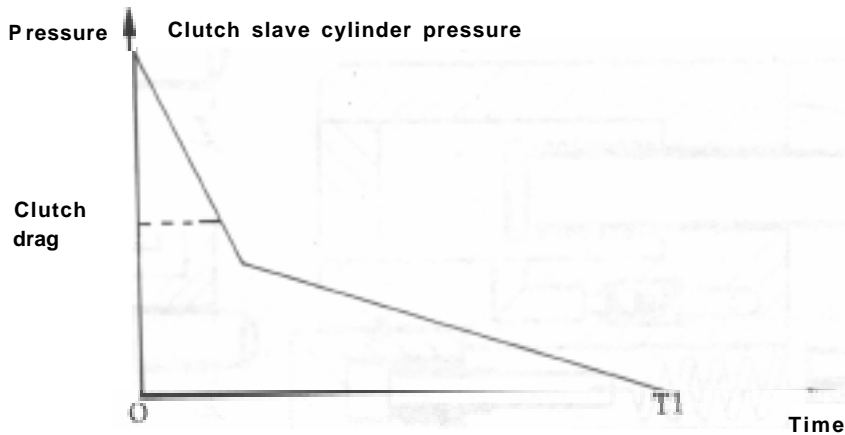

However it is necessary to vary the speed of clutch engagement according to the driver's wishes. To achieve this the phase-change pressure is altered. By reducing this pressure the rapid-drop phase is lengthened which results in the overall time of engagement being reduced.

The limits of this variation are : clutch slip in one sense and jerky engagement in the other.

When driving, this variation is obtained by the rotation of the cam which alters the spring tension in the CRC.

e.g. Under acceleration the pressure on the slide-valve decreases so the overall time of re-engagement decreases (  $T_2$  ).

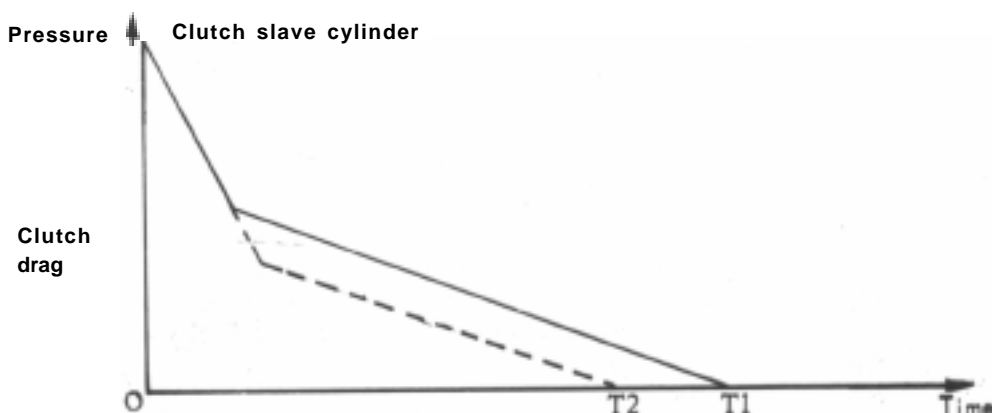

There is a fine static adjustment of the spring in the CRC by means of a second spring, the tension of which is variable by a screw and nut system.

( By tightening the time of re-engagement is reduced ).

- Throttle closing piston :

So that the engine speed is not excessive at the point of clutch re-engagement, it is limited during de-clutching. Mainly this permits the driver to keep the acceleration applied when changing down without affecting the smoothness of clutch engagement.

While the pressure is rising in the slave cylinder, the fluid pushes on the throttle-closing piston. The entry of fluid to the piston is slowed by making it pass a ball with 3 grooves on its seating, the fluid passing by the grooves. The restriction of the fluid is necessary to avoid « hammering » in the hydraulic circuit, and above all to prevent the throttle from being closed too quickly.

The piston moves out and limits the movement of the cam connected to the throttle spindle. The engine speed is limited while the clutch is out.

Upon re-engagement, the pressure drops at the same speed as in the clutch slave cylinder, and the piston returns under the influence of its return spring.

## VI - GEARCHANGE SPEED REGULATOR

**1. Purpose** : The hydraulic fluid which operates the gearchange circuits is not always at the same temperature or pressure when it reaches the hydraulic gear selector. If not corrected, these variations would cause errors in the times for gear operation. To overcome this, the fluid operating the gears passes through a gear change speed regulator mounted on top of the hydraulic gear selector.

**2. Description** : The regulator consists of a cylinder closed at each end by a plug, and in which a hollow piston slides. Some washers, each with a small hole, some central, some offset, held apart by hollow spacers, form a zig-zag restricted fluid passage and are the internal parts of the piston. A carefully calibrated spring positions this piston..

**3. Operation** : Upon entering the regulator the fluid under pressure creates a force  $F$  which tends to move the hollow piston across so that its end partially closes the outlet  $O$ .

- The return spring exerts a force  $T$  on the piston in opposition to  $F$ .
- The fluid under pressure passes through the filter and the various washers to supply the gear circuits.
- The piston is acted upon from one side by the force  $F$  from the fluid, and from the other by the force  $T$  from the spring to which is added therefore  $F_1$  from the back-pressure in the circuits in the gear selector. Depending the values of  $F$  and  $F_1$ , the position of the piston varies, covering the outlet port  $O$  to a greater or lesser extent. By the regulation of this outlet, the pressure is regulated.
  - The force  $F_1$  is variable, its value depends upon, the resistance to flow through the gear selector. If this resistance is high the difference between  $F$  and  $F_1$  decreases and the piston opens the port more : the pressure remains constant. Conversely if this resistance is low  $F_1$  decreases and the piston obscures more of the port, the pressure stays the same.
  - The force  $F$  is variable and depends on the source of pressure, and depending on this value, the outlet port  $O$  will be more or less obstructed.
- It should be noted that the flow of fluid through the hollow piston is such that it is not affected by the viscosity or temperature of the fluid.

NOTE : The position of the nut E, used to set the value  $c$  altered.

# GEAR CHANGE SPEED CONTROL

