

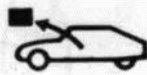

15



XM
842-1/3

1

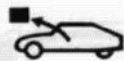
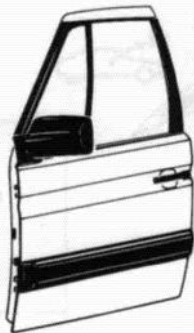

XM 841-1/1

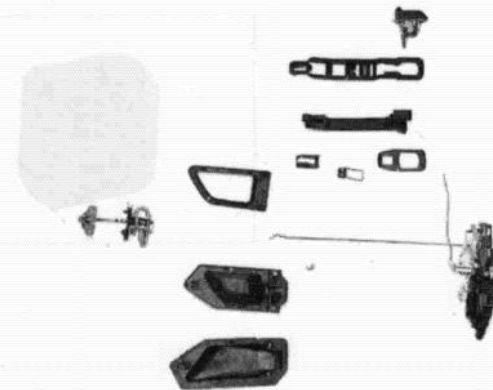
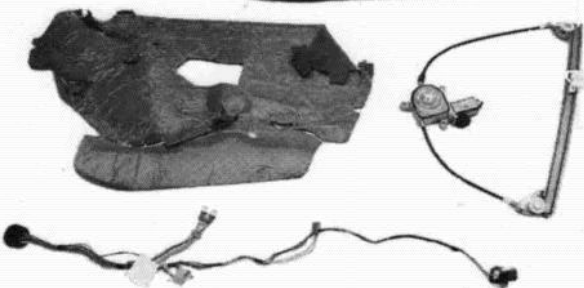
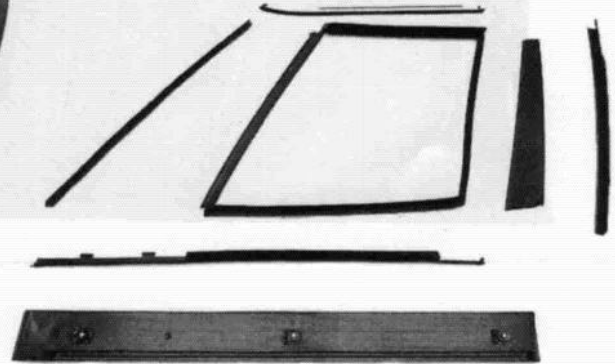
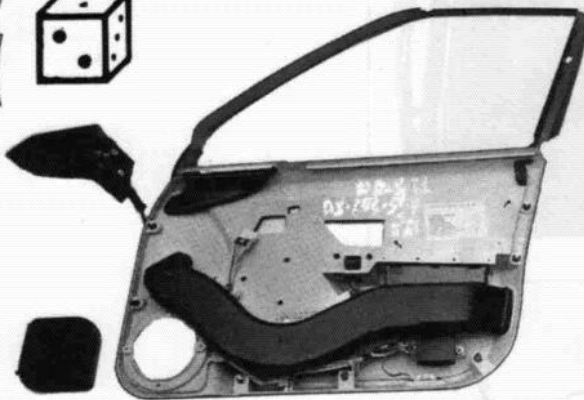
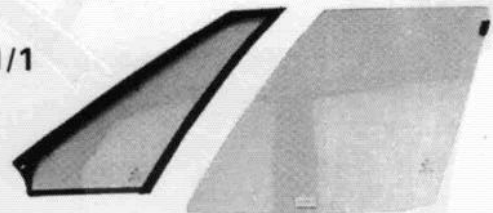
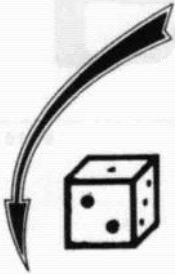

89-13

89-15

89-16

89-77

89-20

8932

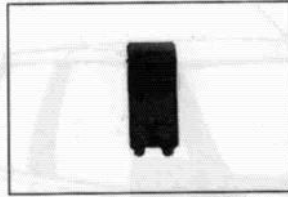
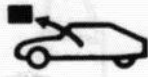

89-684

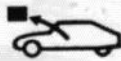

89-63

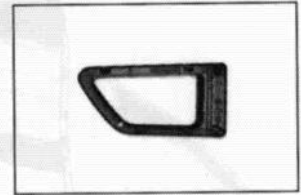

89-16

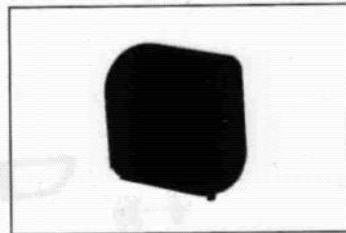
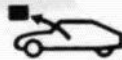

89-17



15



XM
842-1/3

3

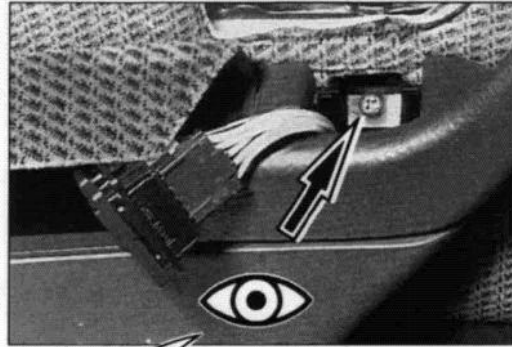

89-65

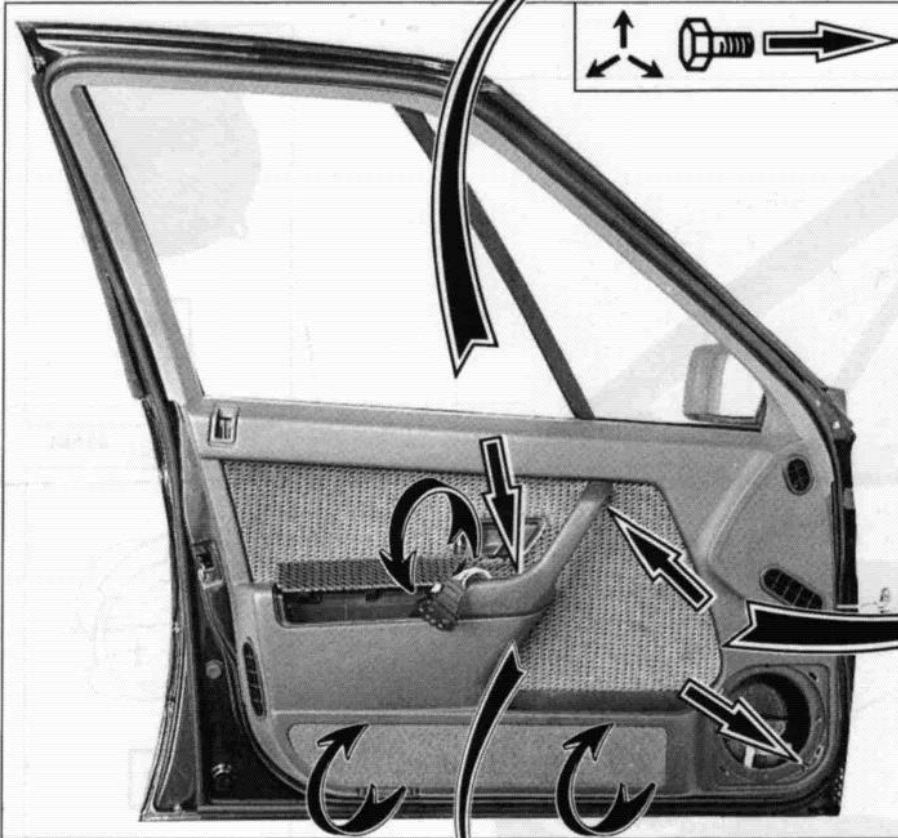
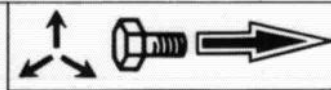

89-683

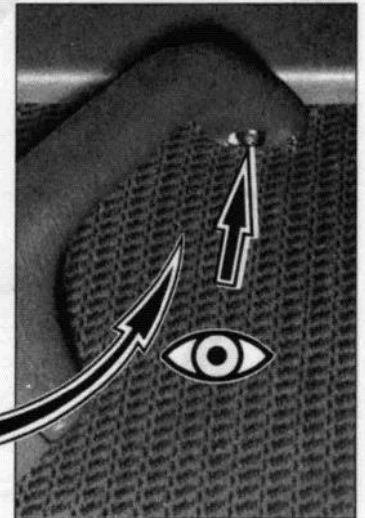

89-66

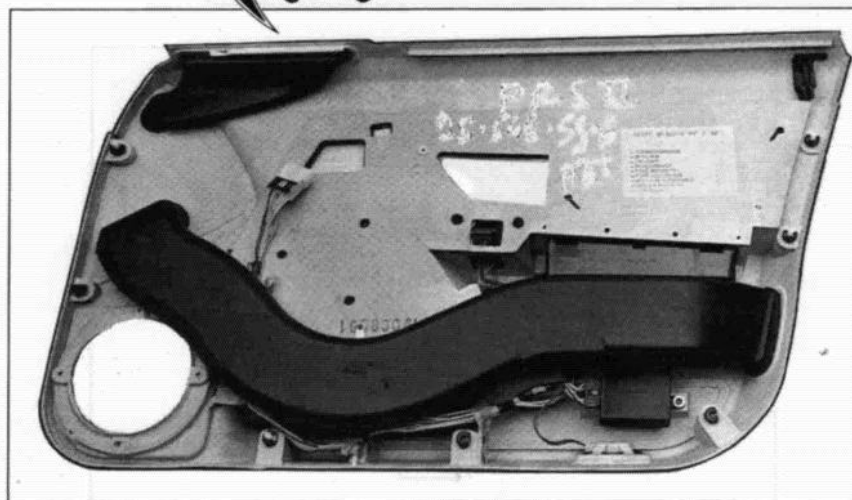

89-17

89-17

89-65

89-66

89-683



1°

2°

3°

4°

5°

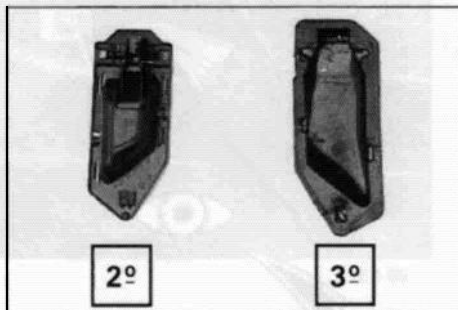

89-16

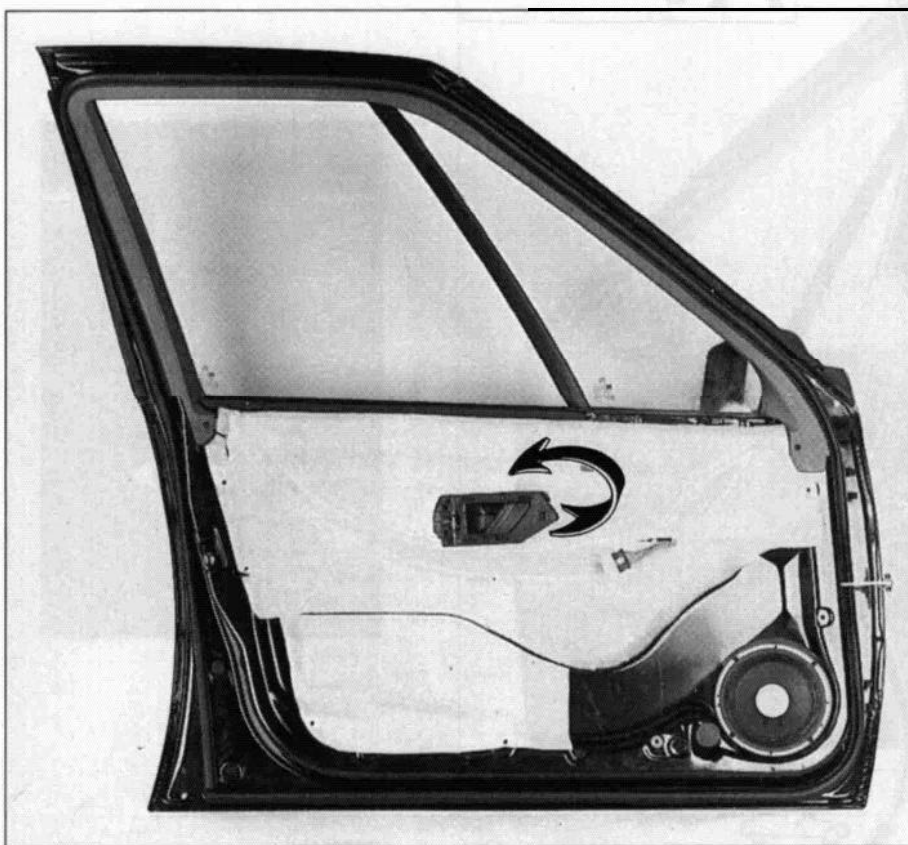

89-62

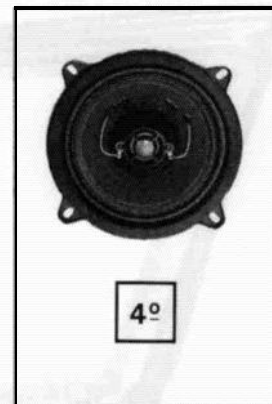

89.884

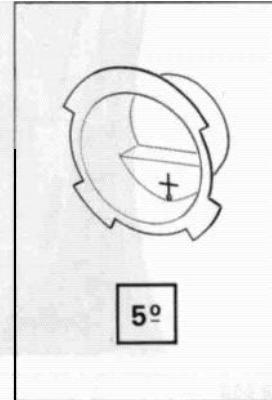

Y.96-7

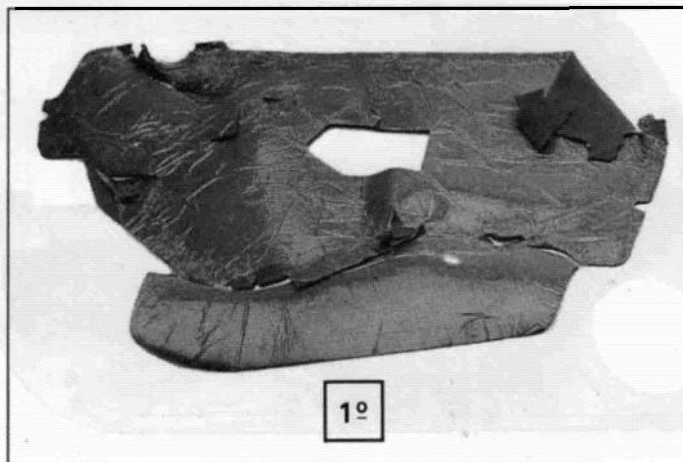

89-15



15

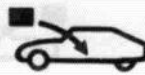

XM
842-1/3

5



1°

2°

9°

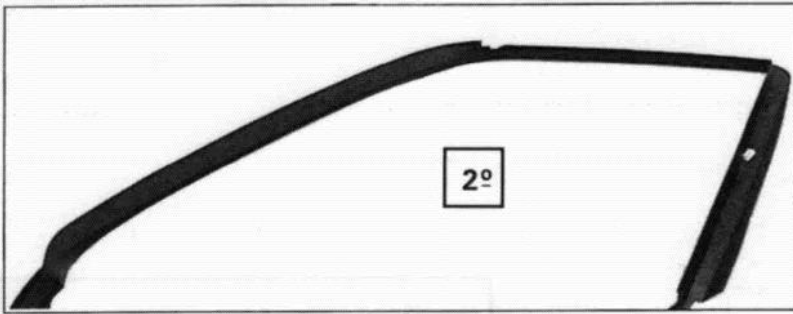

2°

89-17

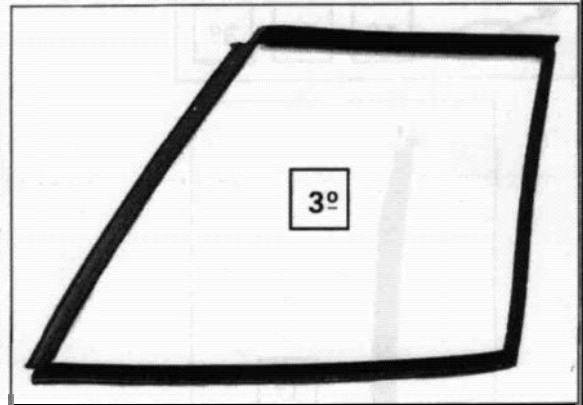

3°

89-13

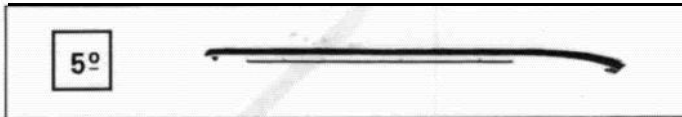

5°

89-13

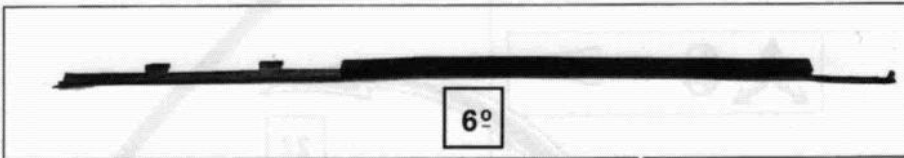

6°

89-93

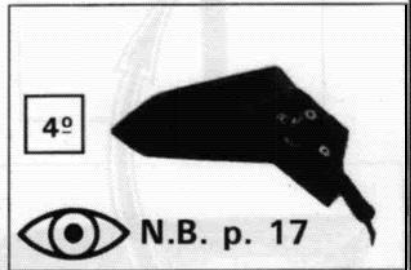

4°

N.B. p. 17

89-17

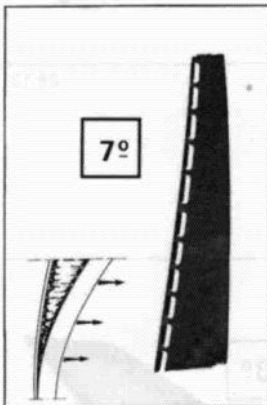

7°

89-13

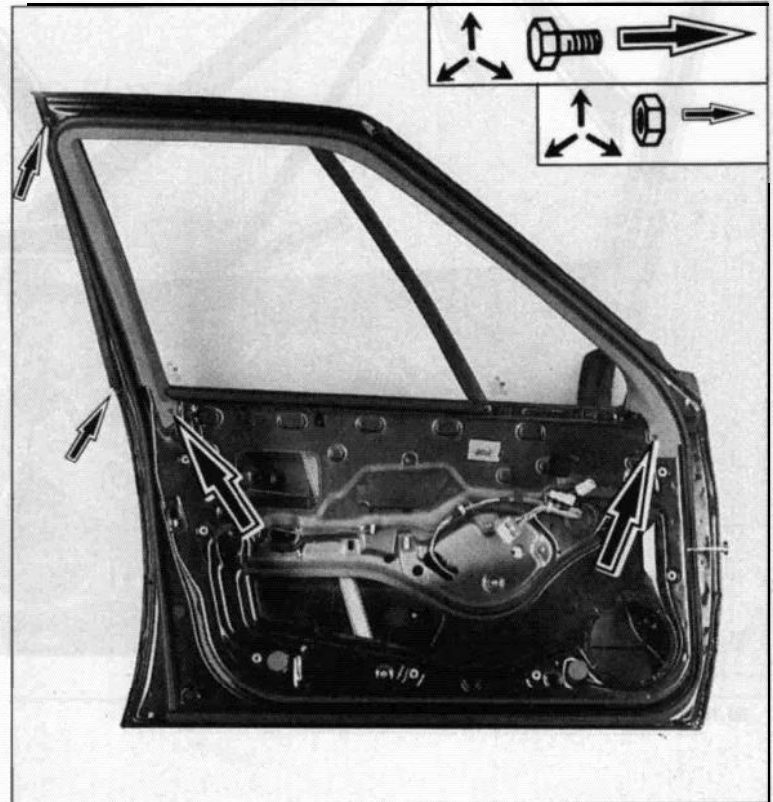

89-61

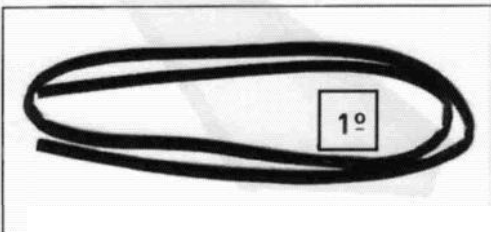

1°

89-15

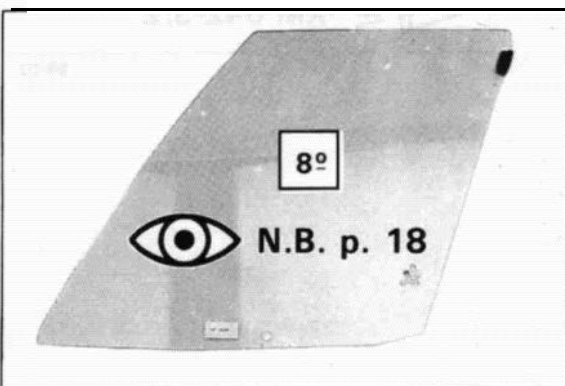

8°

N.B. p. 18

89-20l

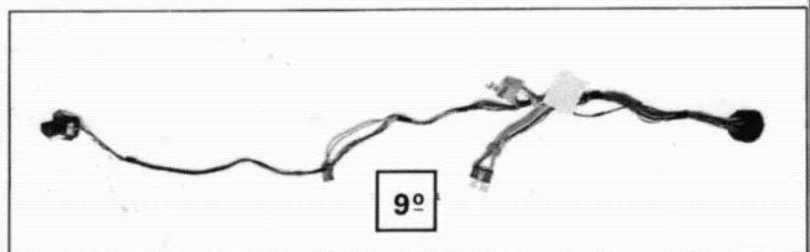

9°

89-15

89-13 89-16 89-17 89-61 89-20l TT.82-5

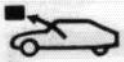
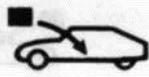

1°

2°

3°

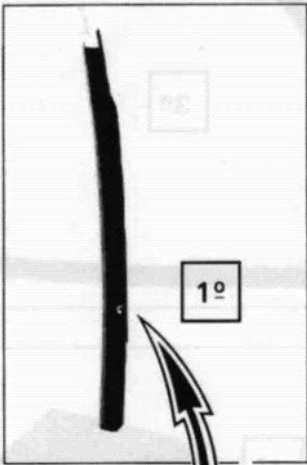

1°

89-13

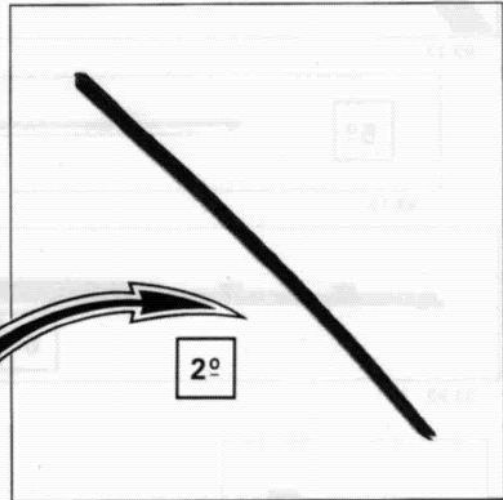
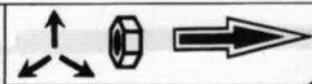

2°

89-13

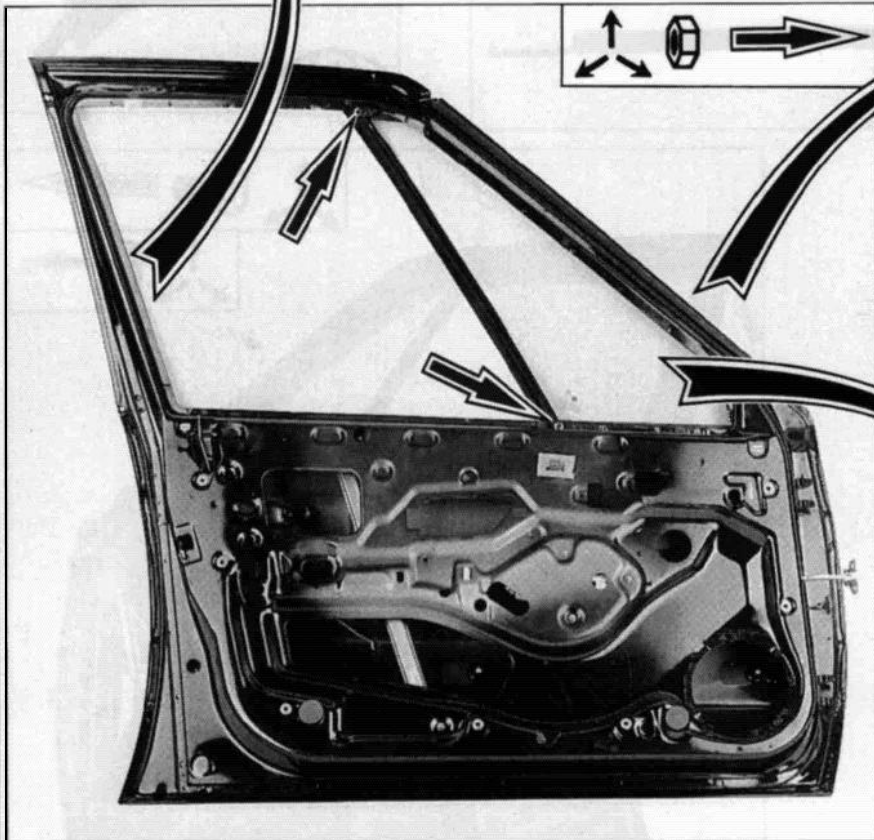

89-182

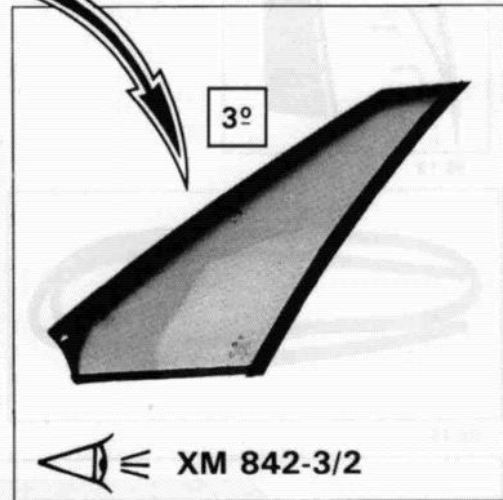

3°

 XM 842-3/2

89-20



15

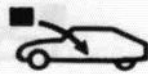
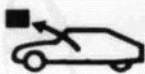

XM
842-1/3

7

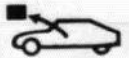

1°

2°

7°



3°

89-16

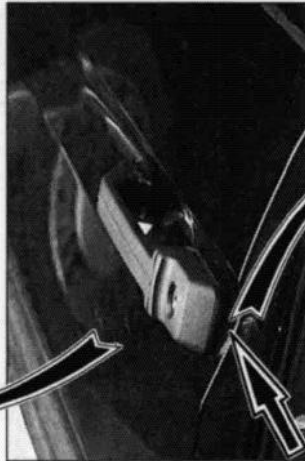

89-74

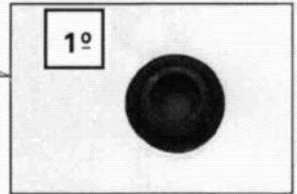

1°

89-43

2°

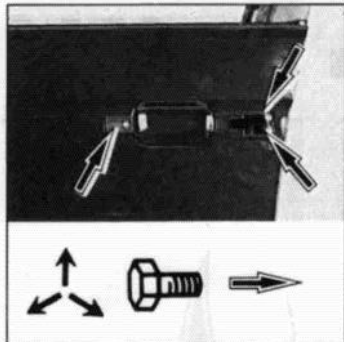
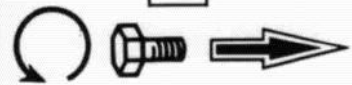

89-40

4°

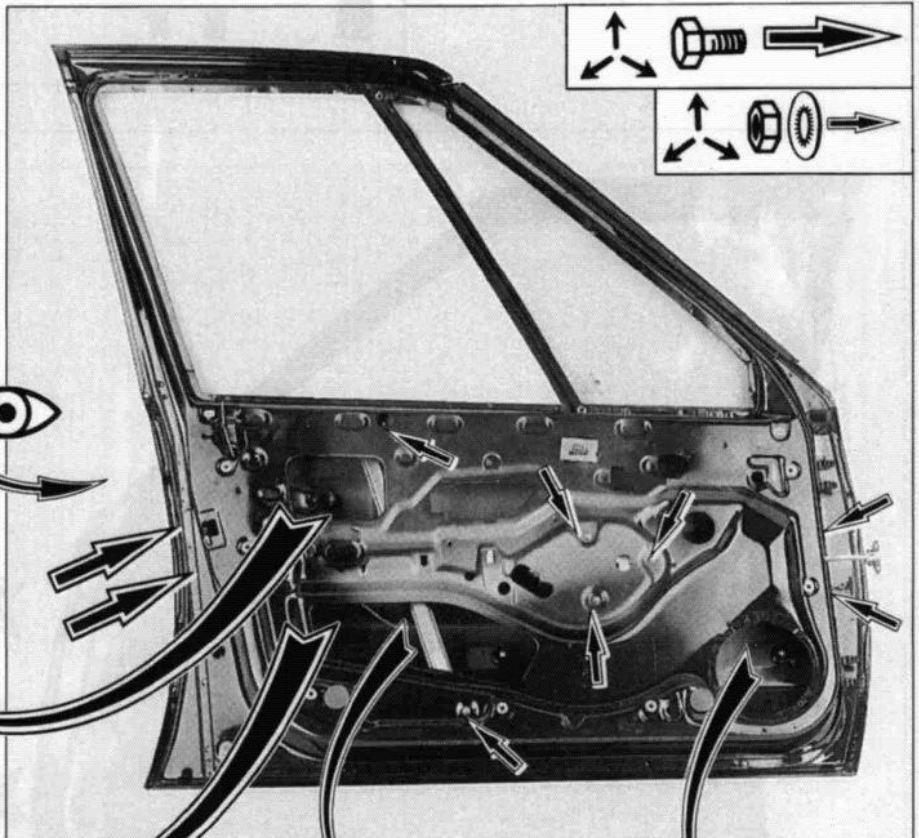

89-39

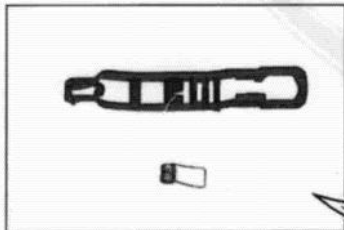
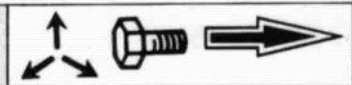

89-16

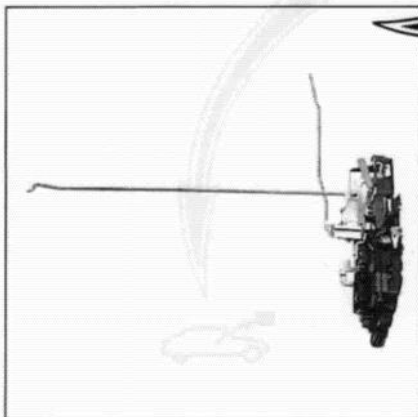

89-16

6°

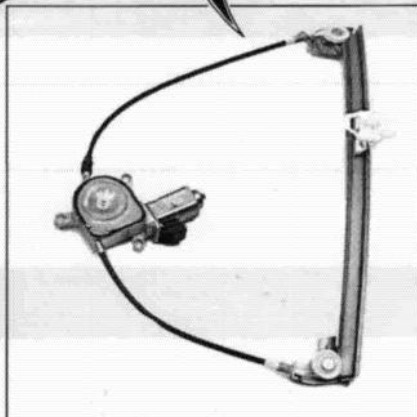

89-15

5°

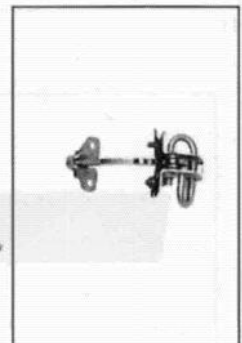

89-16

7°

89-15

89-16

89-39

89-40

89-43

89-74

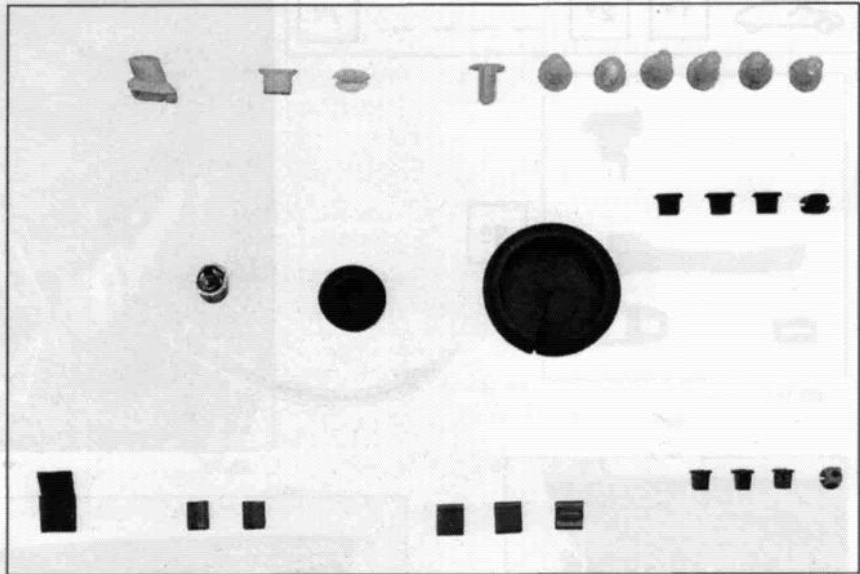
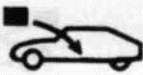
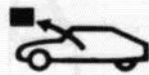

89-43

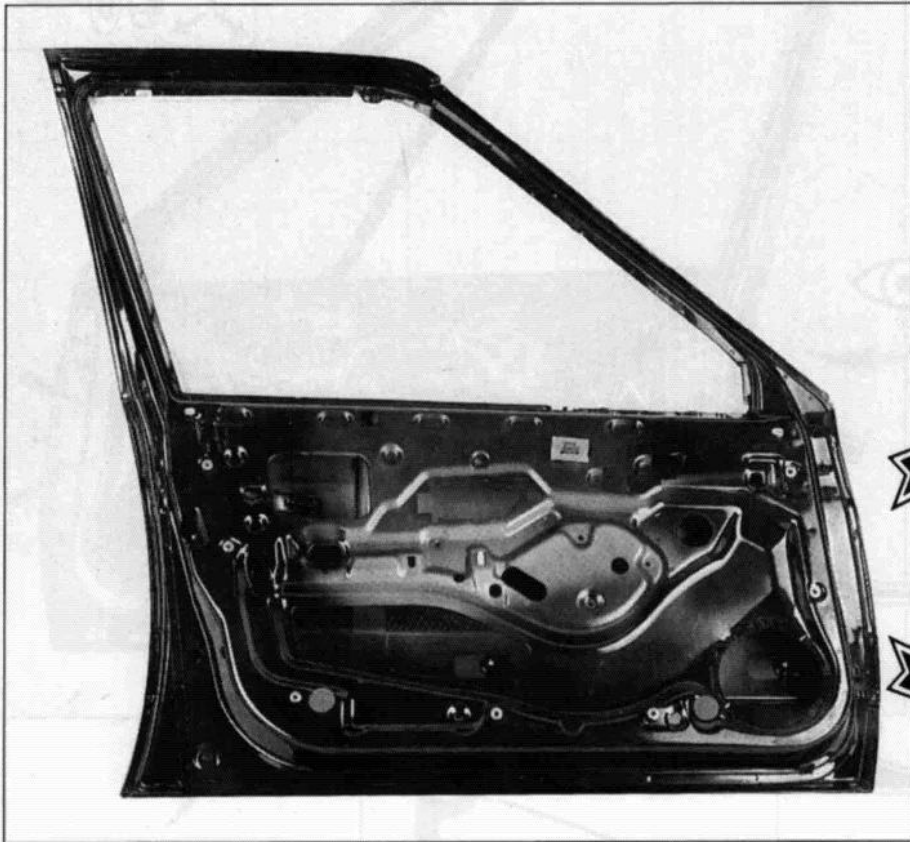

89-41

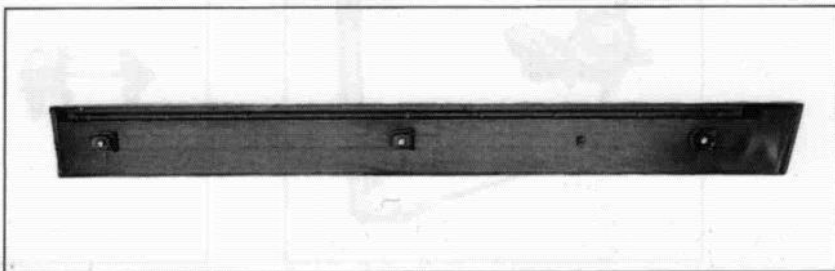

89-13

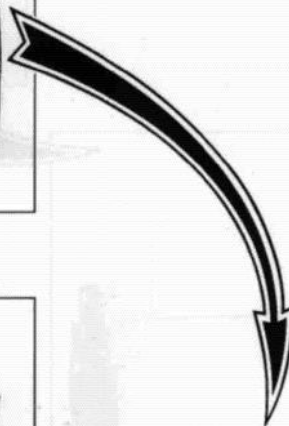
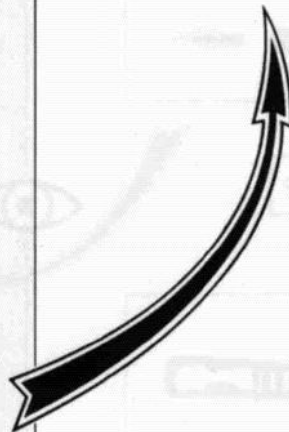
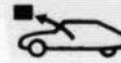



15

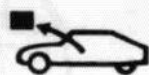

XM
842-1/3

9

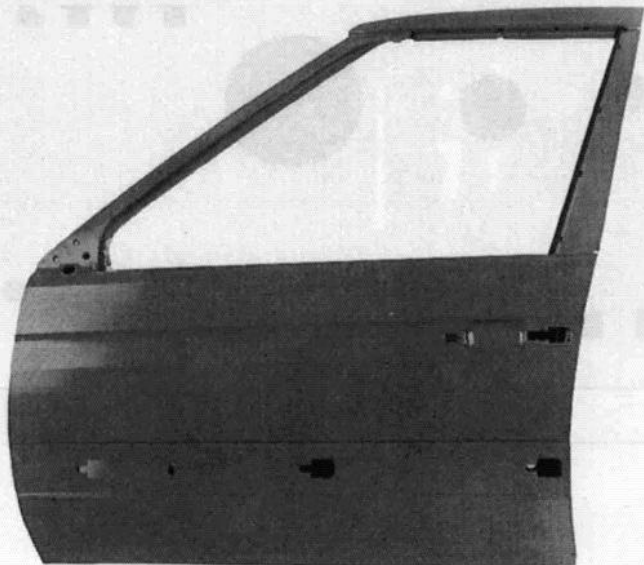

89-183

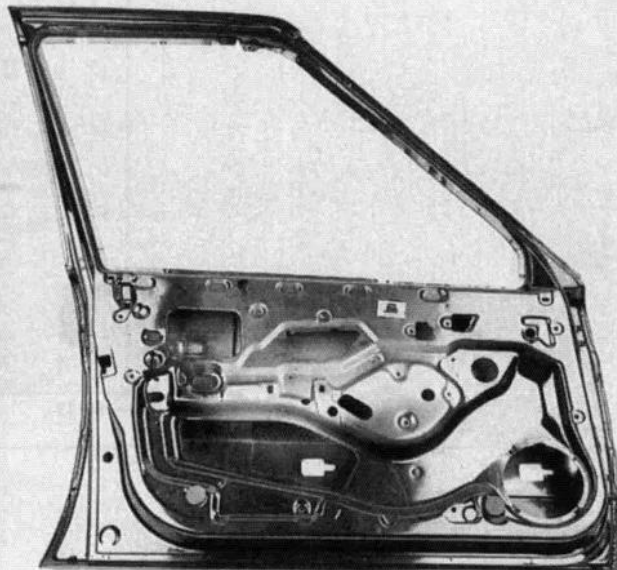

89-14

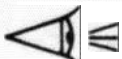

XM 800-00/3

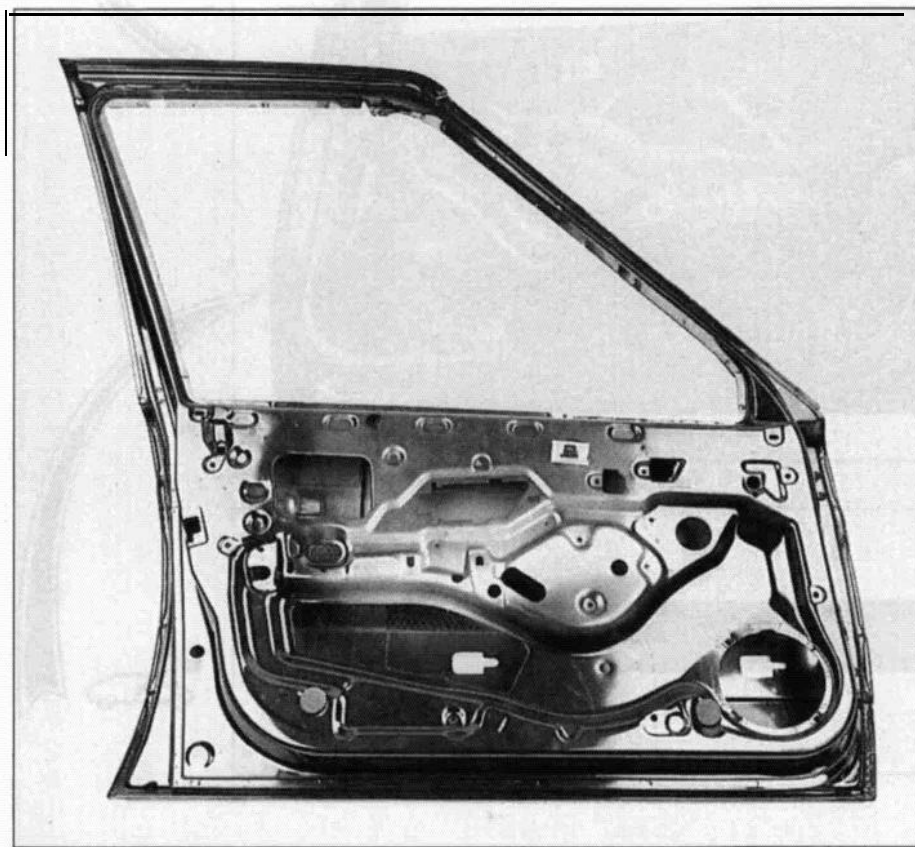

89.14

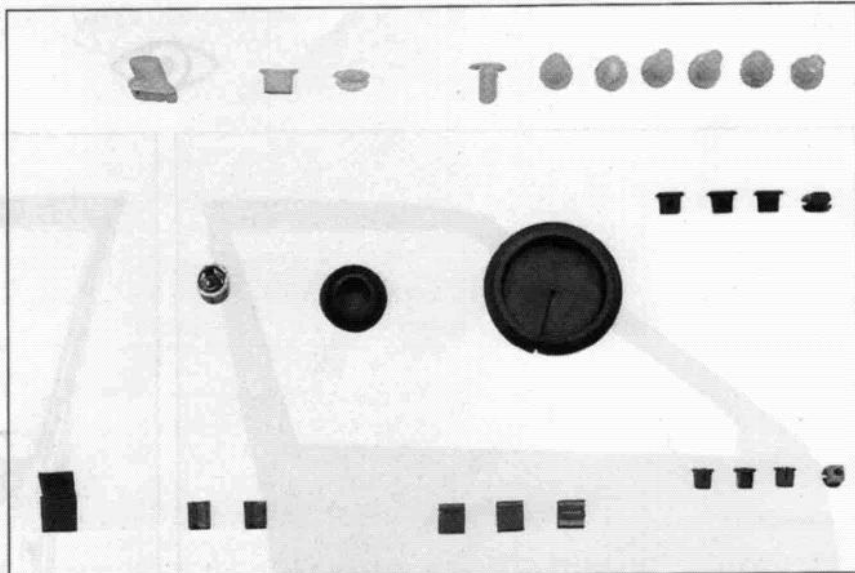
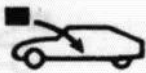

89-43

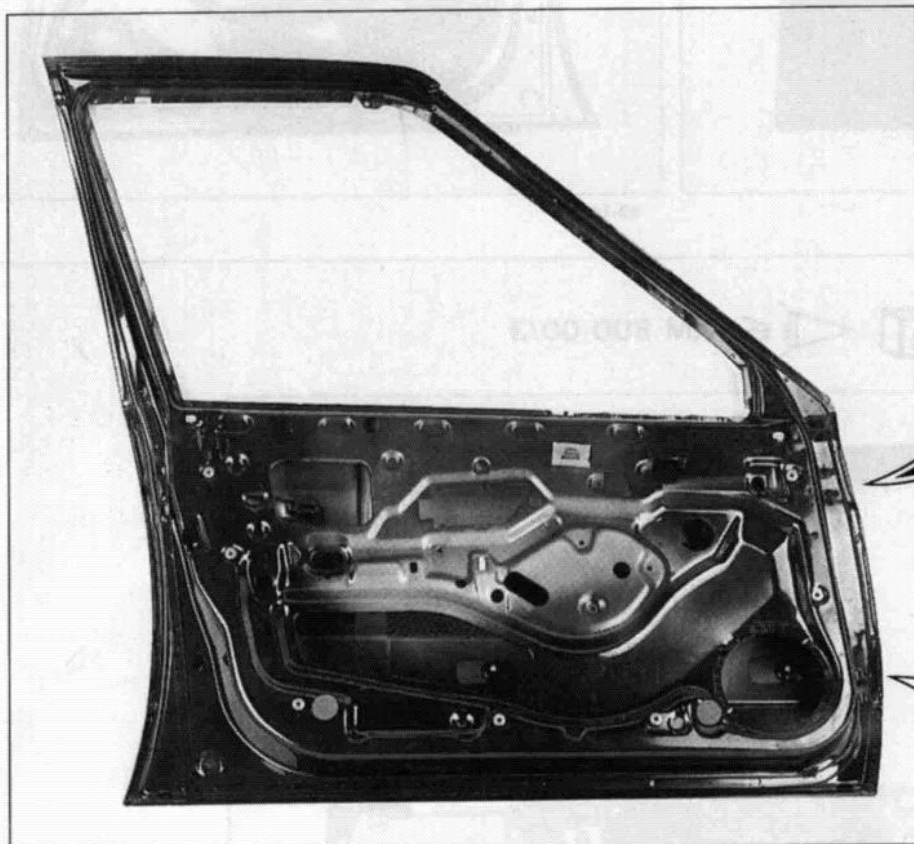

89-41

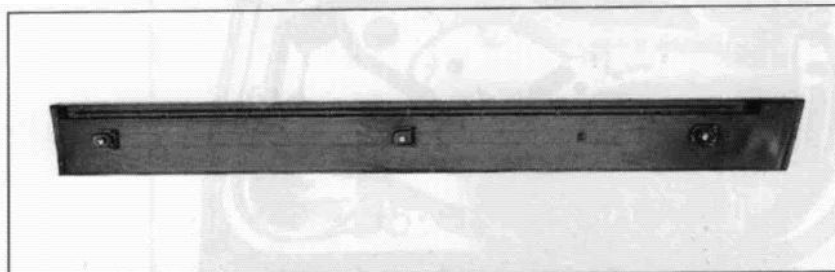

89-13

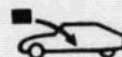



15

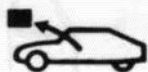

XM
842-1/3

11



1°

2°

7°



89-16

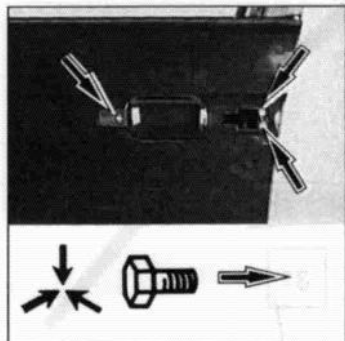

89-40

4°

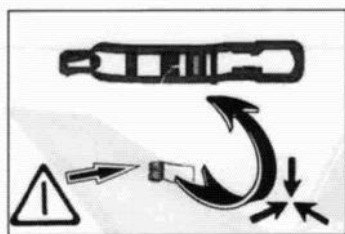

89-16

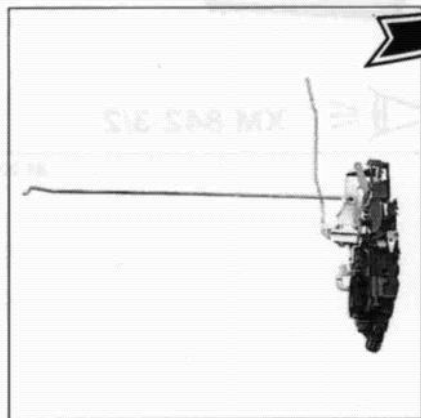

89-16

2°

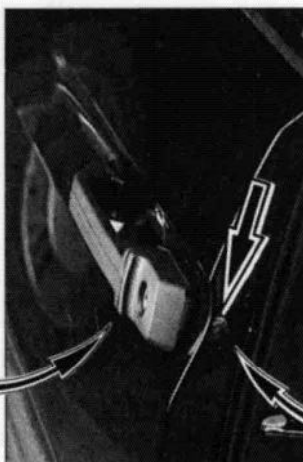

89-74

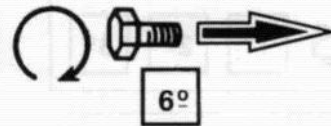

6°

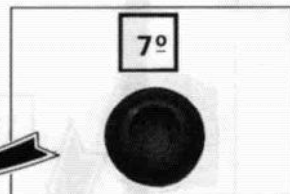

89-43

7°

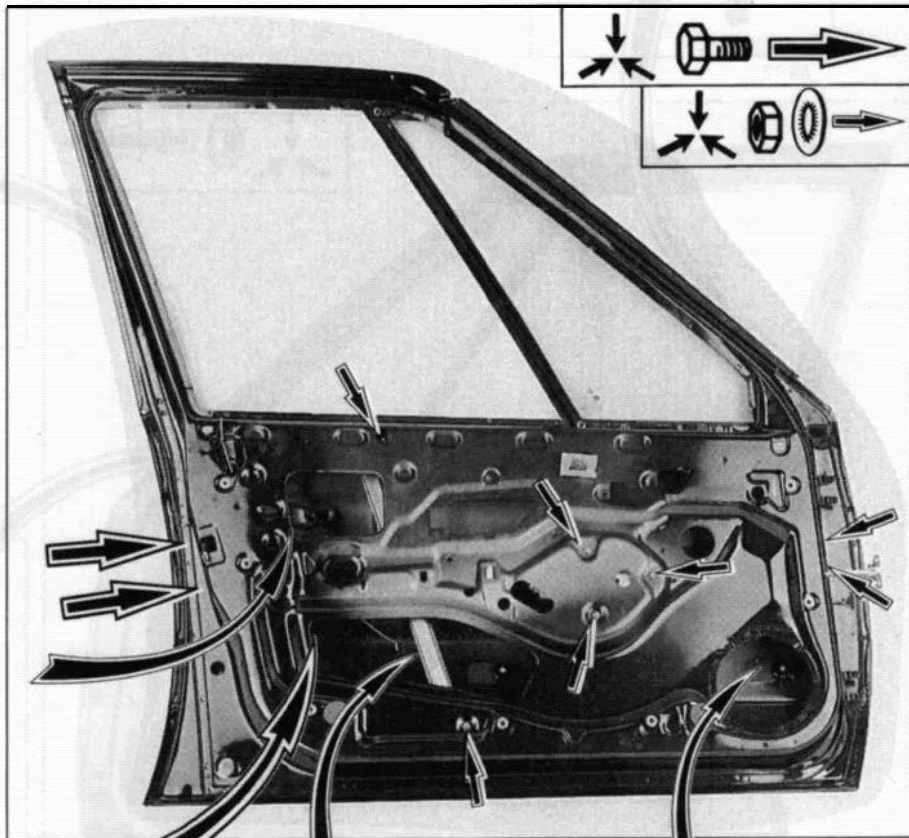

89-39

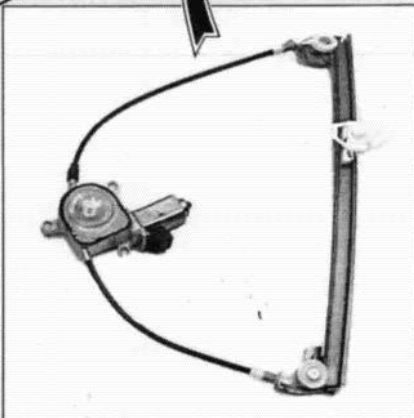
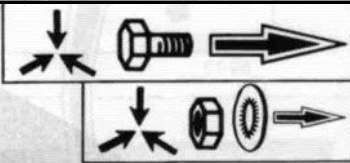

89-15

3°

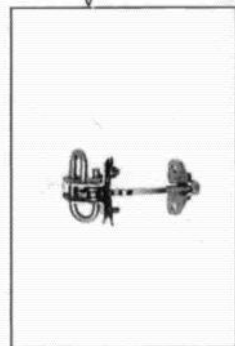

89-16

1°

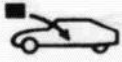
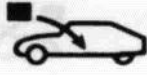
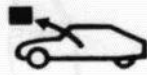

1°

2°

3°

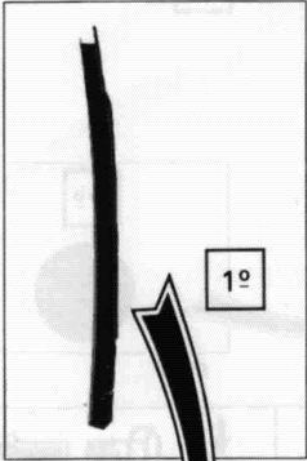

1°

89-13

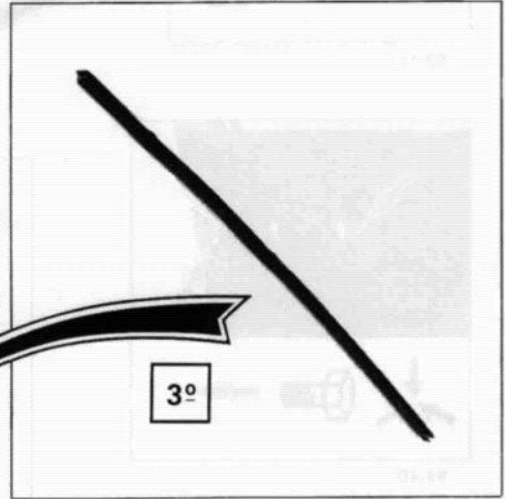

3°

89-13

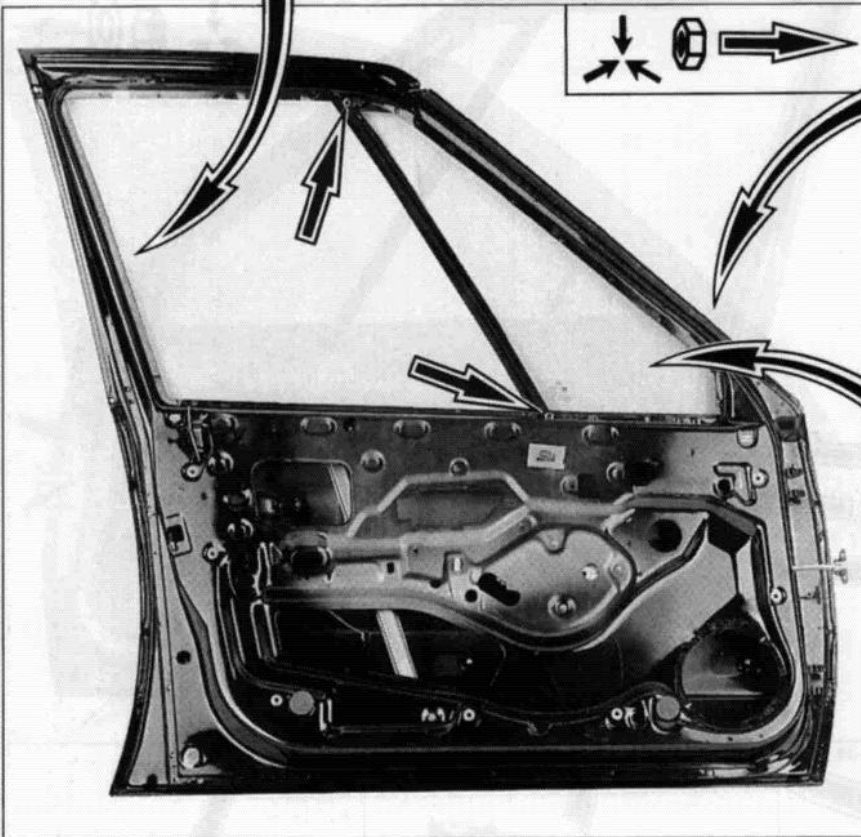

89-182

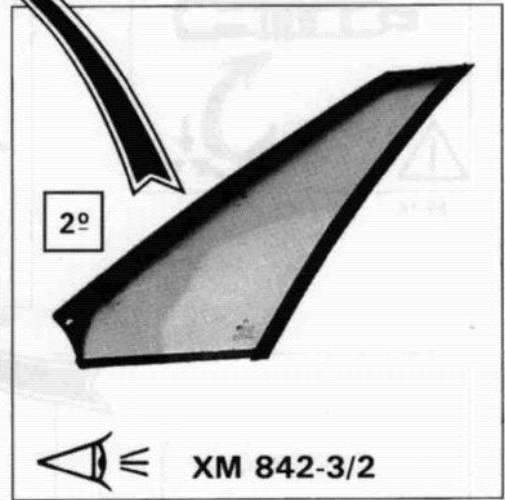

2°

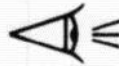

XM 842-3/2

89-20



15

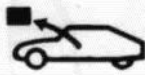

XM
842-1/3

13



1°

2°



9°

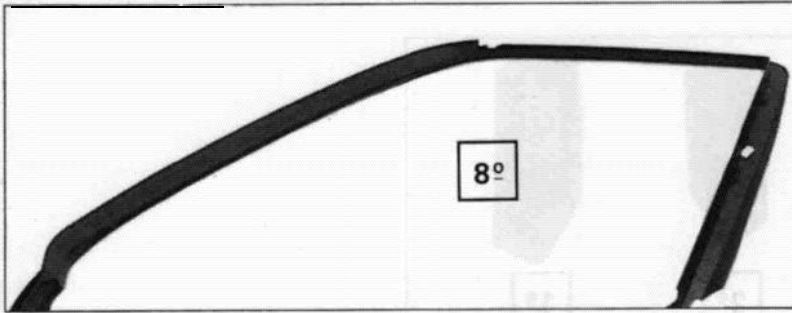

89-17

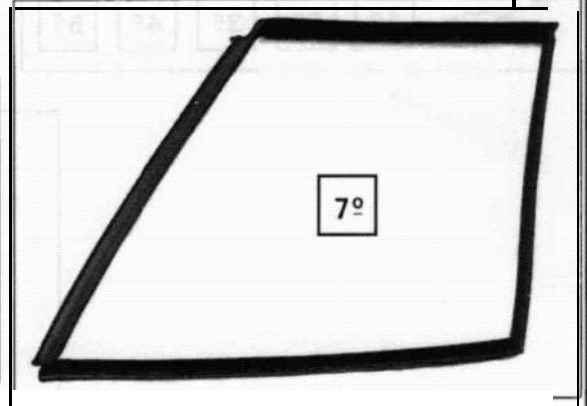

89-13

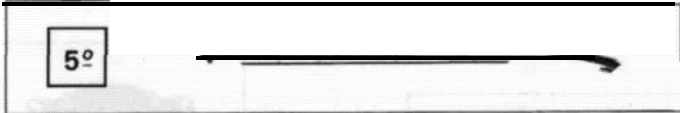

89-13

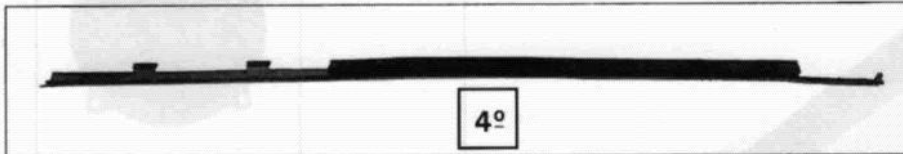

89-13

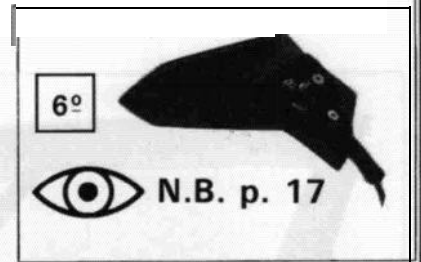

89-17

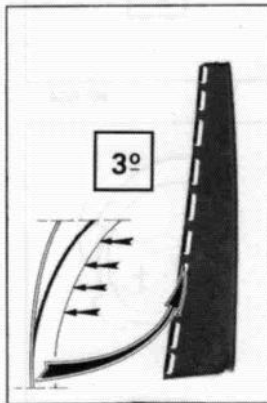

89-13

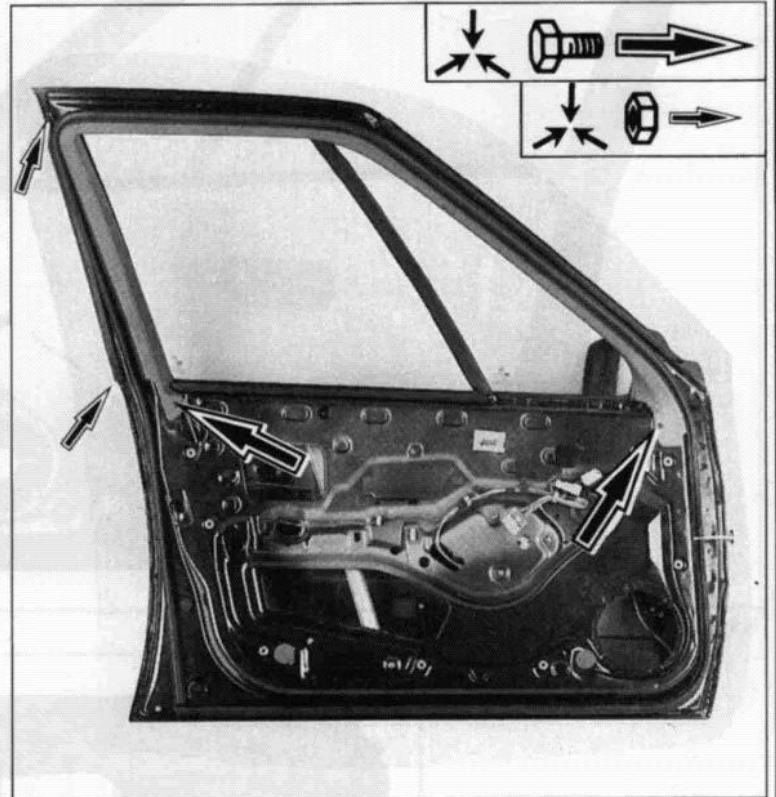

89-61

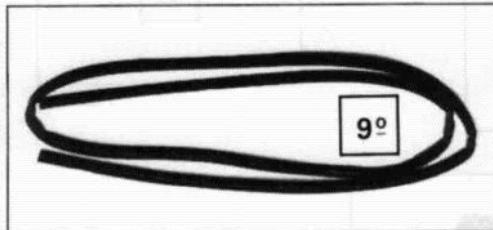

89-15

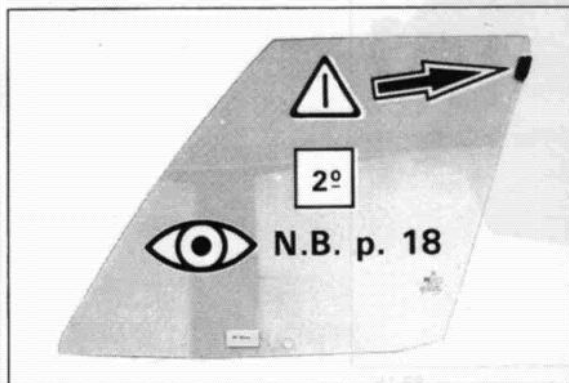

89-20

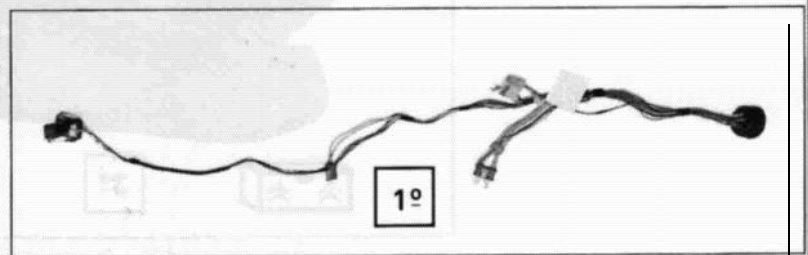

89-15

89-13 89-15 89-17 89-20 89-61 TT.82-5

14

XM
842-1/3

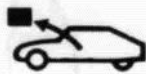

15

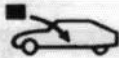

1°

2°

3°

4°

5°

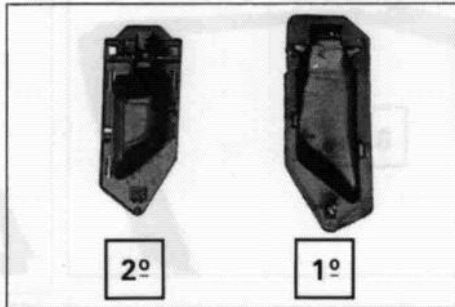

89-16



89-62

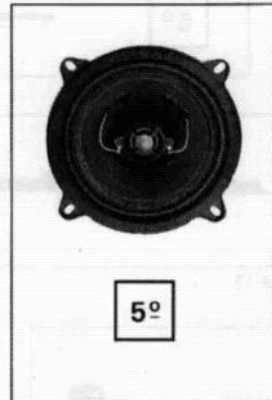

89-684

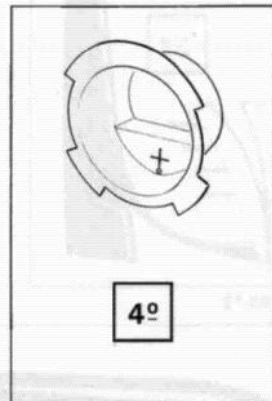

Y.96-7

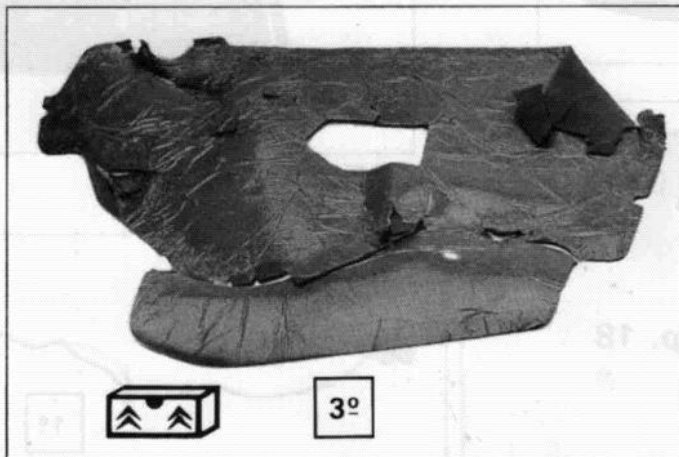

89-15



15

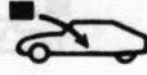
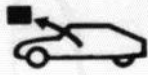

XM
842-1/3

15

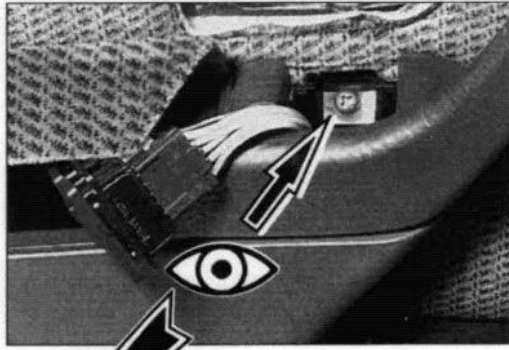

89-65

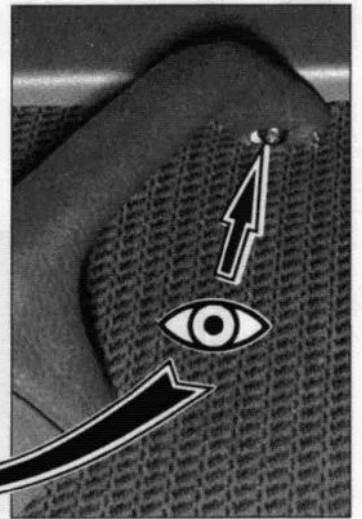

89-66

89-683

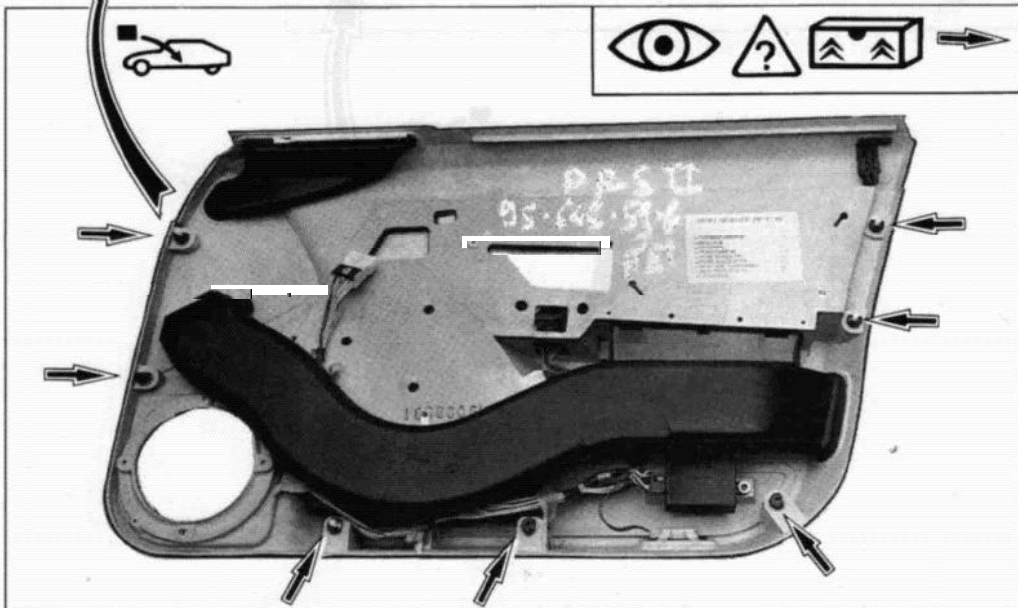

89-17

89-17

89-65

89-66

89-683

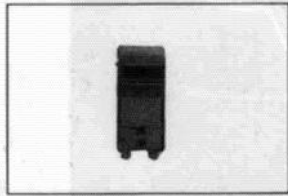
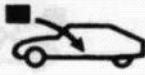
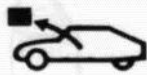

89-684



89-63

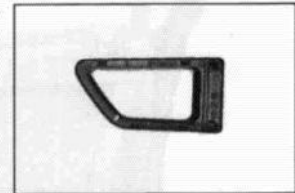

89-16

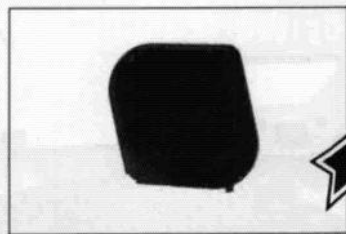

89-17





15

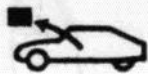

XM
842-1/3

17



N.B.

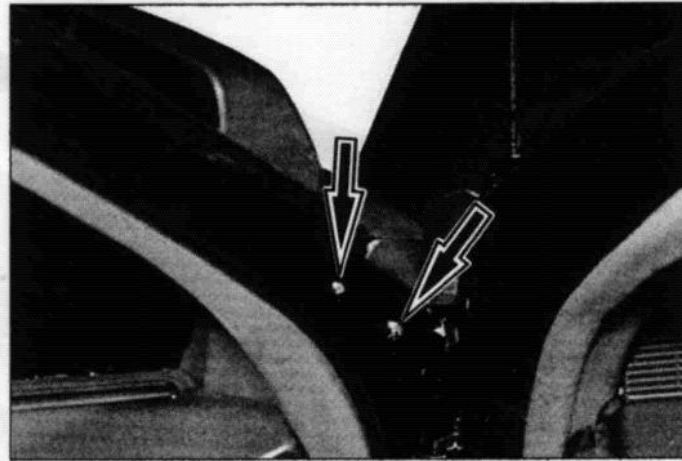

89-71

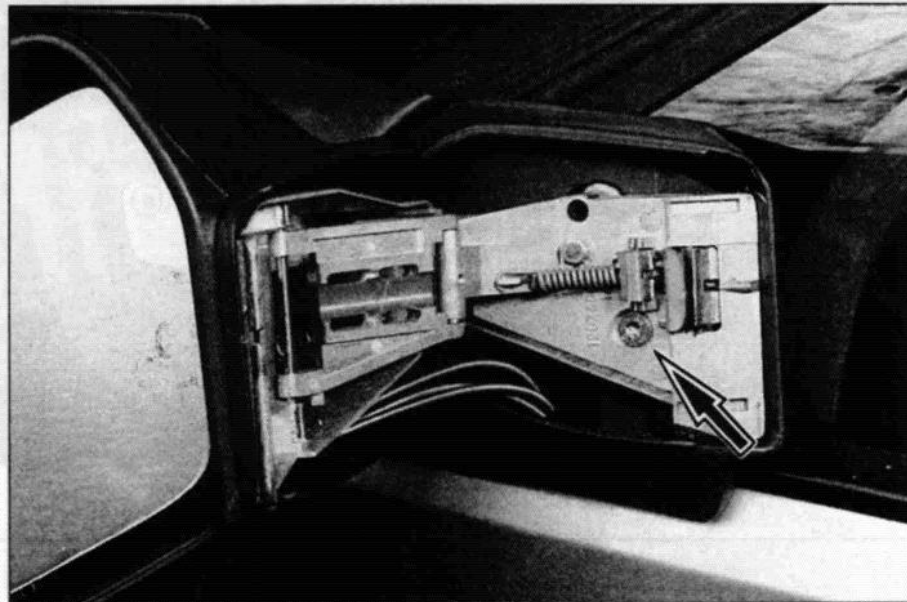

89.705

Observed: Overstated for it like an important bit for more to do and more...
The painting and fitting are not done in the same way as the other...
1/2 - 1/2 in. screw L
Should be removed from all these projects (B) which is left in place...
Help for a better...

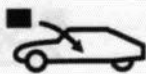

OBSERVERA

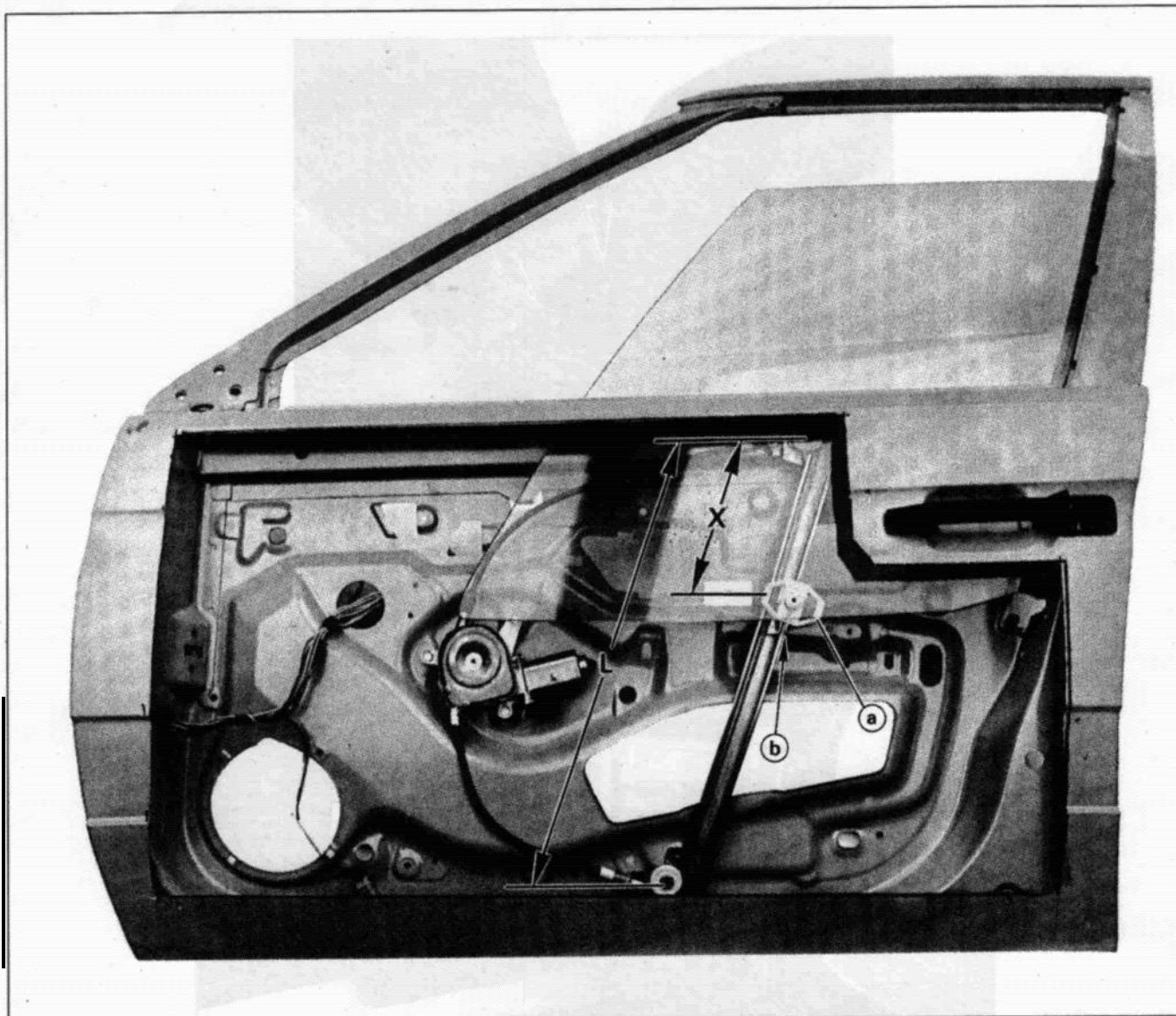

Observera: Ovanstående foto är inte en representativ bild för arbete på dörr och dess invändiga mekanik. Vid uttagning och isättning av en sidoruta i en framdörr, veva ner rutan så att sträckan X till fästet (a) är ungefär $1/3 - 1/2$ av sträckan L.

Sidorutan demonteras genom att lossa proppen (b), vilken är fäst i en plastremsa.

Klipp inte av plastremsan.