



5



AUTO

XM  
350-00/1

1

# 4 HP 18

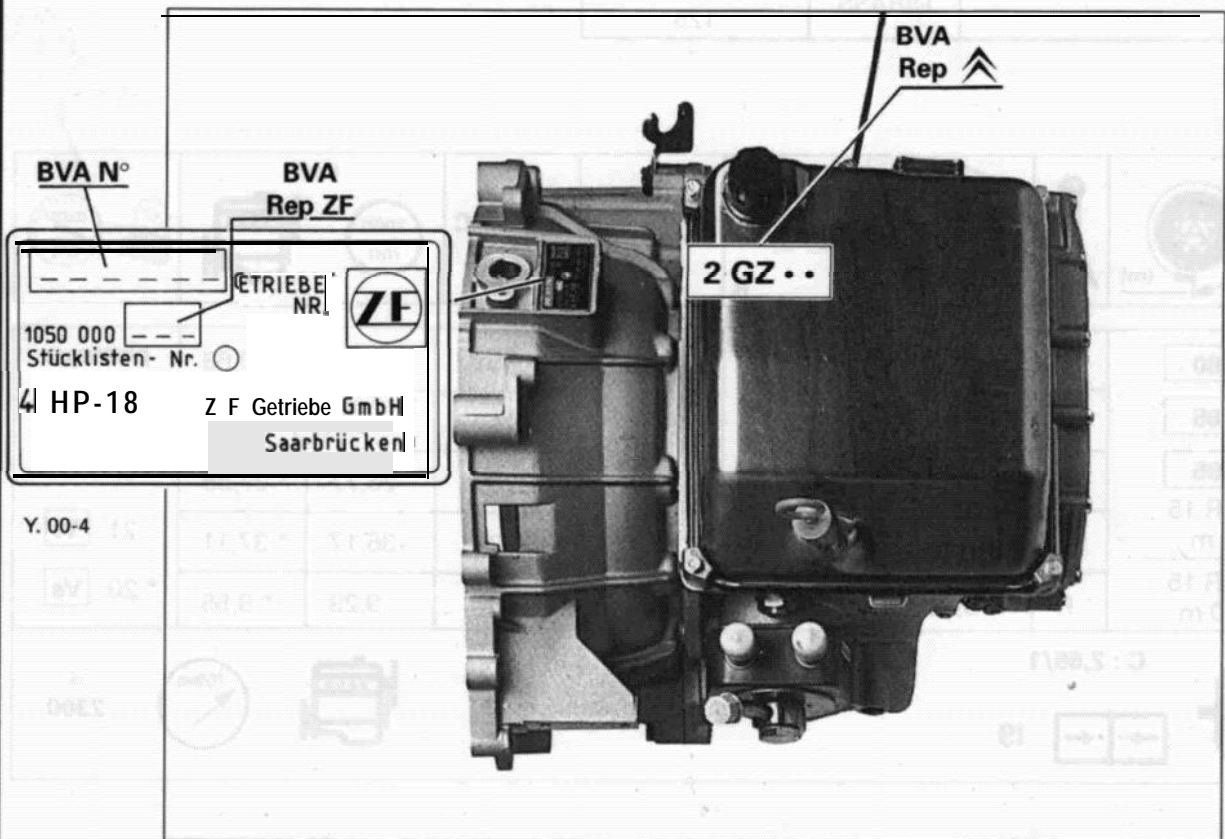
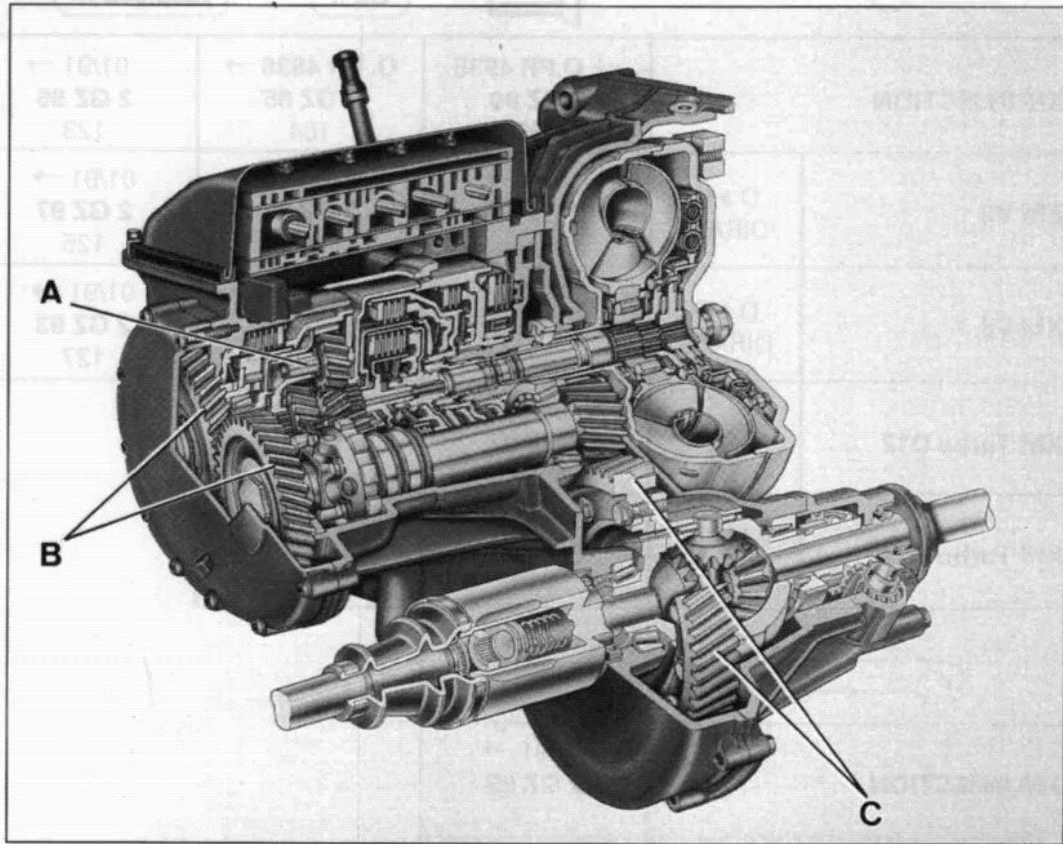

**BVA N°**

**BVA Rep ZF**

1050 000  
Stücklisten- Nr.

4 HP-18

GETRIEBE NR. 

Z F Getriebe GmbH  
Saarbrücken

Y. 00-4

70-276



				ZF 1050.000 ...
XM INJECTION		→ O.PR 4935 <b>2 GZ 80</b> 093	O. PR 4936 → <b>2 GZ 85</b> 104	01/91 → <b>2 GZ 95</b> 123
XM V6	D à G DIRAVI	04/90 → <b>2 GZ 78</b> 092	07/90 → <b>2 GZ 88</b> 106	01/91 → <b>2 GZ 97</b> 125
XM V6	D à D DIRASS	04/90 → <b>2 GZ 79</b> 097	07/90 → <b>2 GZ 90</b> 108	01/91 → <b>2 GZ 93</b> 127
XM Turbo DI2	Moteur P8A	04/91 → <b>2 GZ 87</b> 118	10/91 → <b>2 GZ 5 A</b> 132	
XM Turbo DI2	Moteur PHZ	04/91 → <b>2 GZ 91</b> 132	10/91 → <b>2 GZ 5 A</b> 108	
XM INJECTION		09/91 → <b>2 GZ 95</b> 123		
XM V6	DIRAVI DIRASS	09/91 → <b>2 GZ 97</b> 125		

						A x B x C	Km/h			
<b>2 GZ 80</b>	1	0,387				0,092	10,36	* 10,68	plastique	
<b>2 GZ 85</b>	2	0,709	56	18		0,169	18,98	* 19,58	25	
<b>2 GZ 95</b>	3	1	x	x		0,238	26,77	* 27,55	x	
195/60 R 15 1,875 m	4	1,351	55	77		0,321	36,17	* 37,11	21 <b>Vi</b>	
195/65 R 15 * 1,930 m	R	0,347				0,082	9,29	* 9,55	" 20 <b>Ve</b>	
c : 2,66/1									≈ 2300	



5

**XM** AUTO

350-00/1

3

**A x B x C**

<b>2 GZ 78</b> <del>2 GZ 88</del> <b>2 GZ 97</b>  205/60 R 15 1, 920 m	1	0, 387	59 x	18 x	0, 100	11,60	(DIRAVI) ACIER	
	3	0, 709 1			0, 184 0, 260	21,25 29,97		25
	4	1, 351			0, 351	40,50		x
	R	0, 347			0, 090	10,40		20

**C : 1,88/1**
**≈ 2000**

<b>2 GZ 79</b> <del>2 GZ 88</del> <b>2 GZ 93</b>  205/60 R 15 1, 920 m	1	0, 387	59 x	18 x	0, 100	11,60	(DIRASS) plastique	
	3	0, 709 1			0, 184 0, 260	21,25 29,97		25
	4	1, 351			0, 351	40,50		x
	R	0, 347			0, 090	10,40		20

**C : 1,88/1**
**≈ 2000**

<b>2 GZ 87</b> <del>2 GZ 84</del> <b>2 GZ 5A</b>  195/65 R 15 1, 930 m	1	0, 387	56 x	21 x	0, 110	12,77	plastique	
	3	0, 709 1			0, 202 0, 285	23,40 33,00		25
	4	1, 351			0, 385	44,60		x
	R	0, 347			0, 099	11,45		20

**C : 2,40/1**
**≈ 2300**



RAPPORT	EMBRAYAGES			FREINS			ROUES LIBRES		
	A	B	E	C'	D	C	F	G	H
1	•				•			▪	•
2				▪		•	▪		•
3	•		•			•			•
4			•	•		•			
M. AR		•			•				•

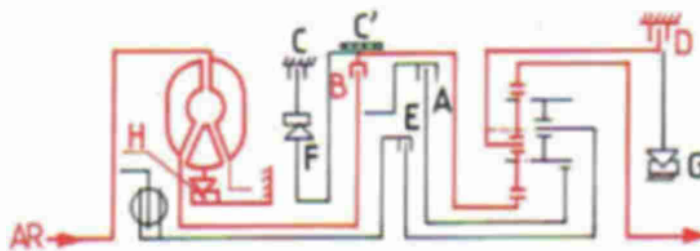
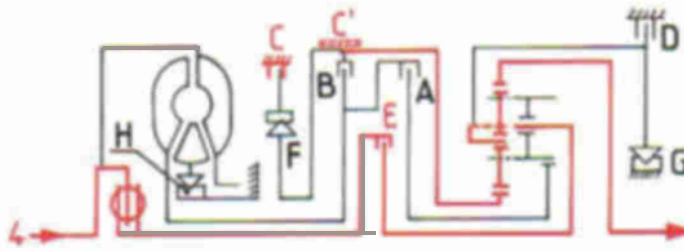
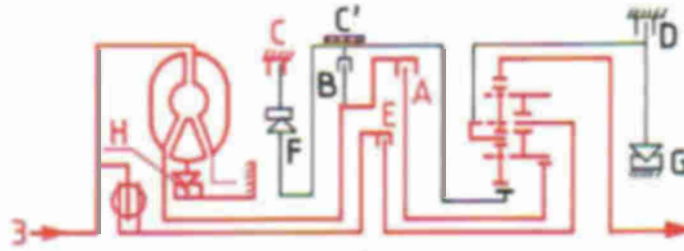
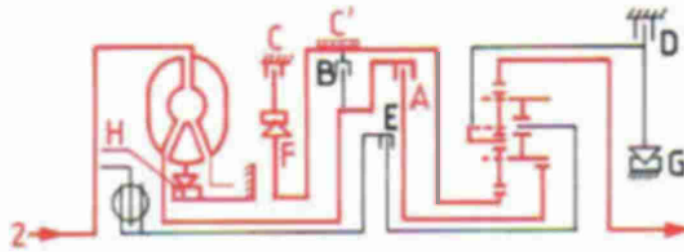
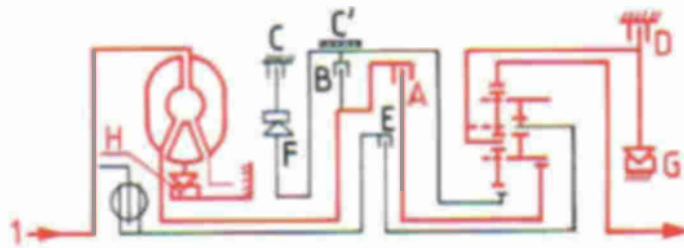

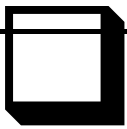

5



AUTO

350-00/1

5

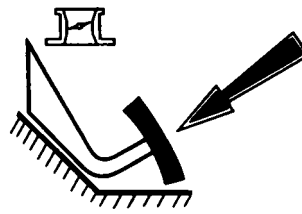

XM. INJECTION	1 - 2	2 - 3	3 - 4	- 4 - 3	3 - 2	2 - 1
	49 à 55	87 à 107	134 à 152	122 à 144	75 à 97	45 à 50

XM. V6	1 - 2	2 - 3	3 - 4	4 - 3	3 - 2	2 - 1
	55 à 62	98 à 120	150 à 169	136 à 160	84 à 108	51 à 56

XM. Turbo DI2	1 - 2	2 - 3	3 - 4	4 - 3	3 - 2	2 - 1
	45 à 52	91 à 98	125 à 145	110 à 132	87 à 94	39 à 47

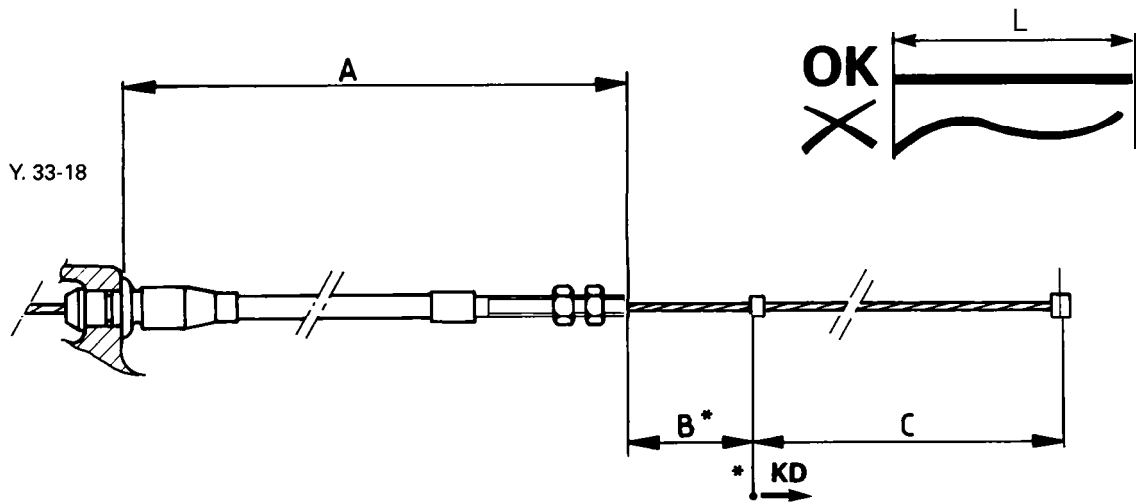

	$A \pm 2$	$B \begin{matrix} +1 \\ 0 \end{matrix}$	$C \pm 5$	
XM. INJECTION	938	43	84	2 GZ 80 2 GZ 85
	1005	43	87,5	2 GZ 95
XM. V6	1005	46	96,5	
XM. Turbo DI2	1075	46	273	

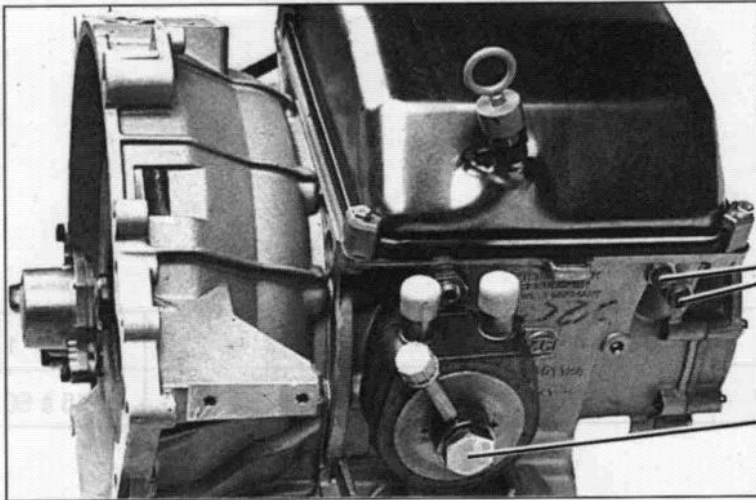

**1,5 mdaN**

**5 mdaN**

90-290

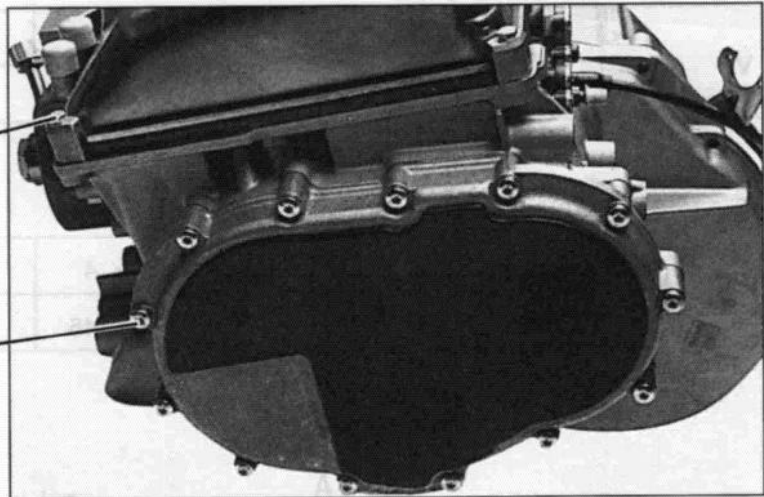

**0,6 mdaN**

**1 mdaN**

90-289

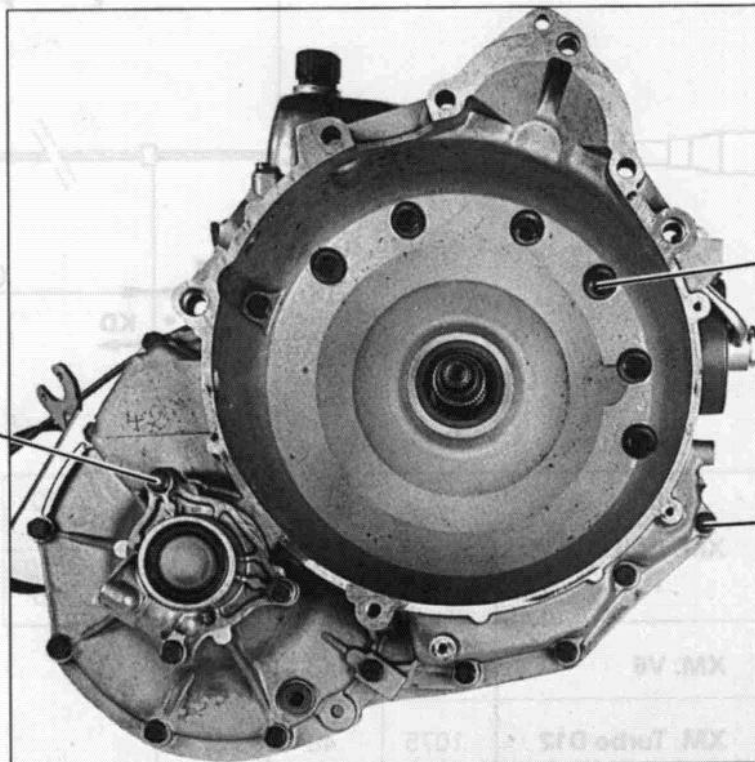

**2,3 mdaN**

**2,3 mdaN**

**2,3 mdaN**

90-755



5



AUTO

XM  
350-00/1

7

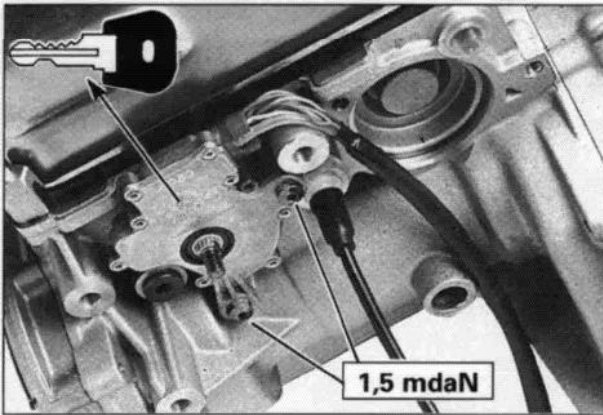

90-274

20 000 km



4,5 mdaN

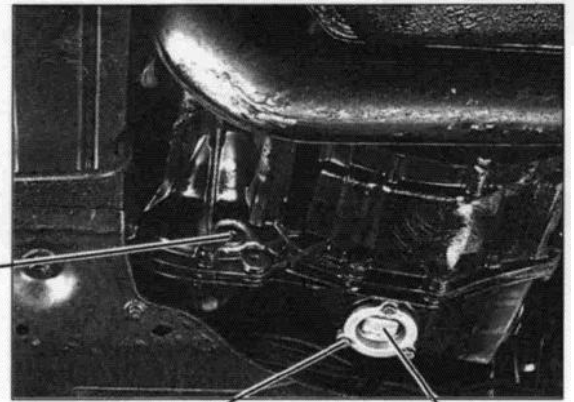

90-303

100 000 km

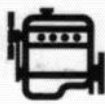
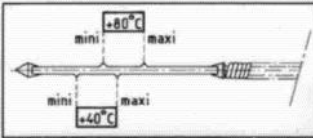

X  
min



"p"

0,8 mdaN

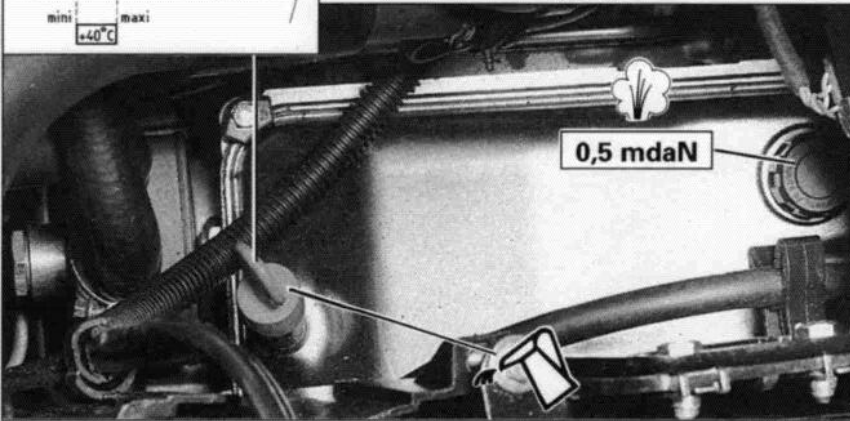

90-255

**TOTAL FLUIDE ATX  
(Total Dexron D20 356)**

XM		
2 L. Injection	7,5 L	2,4 L
V6 D12 turbo	7,8 L	2,7 L

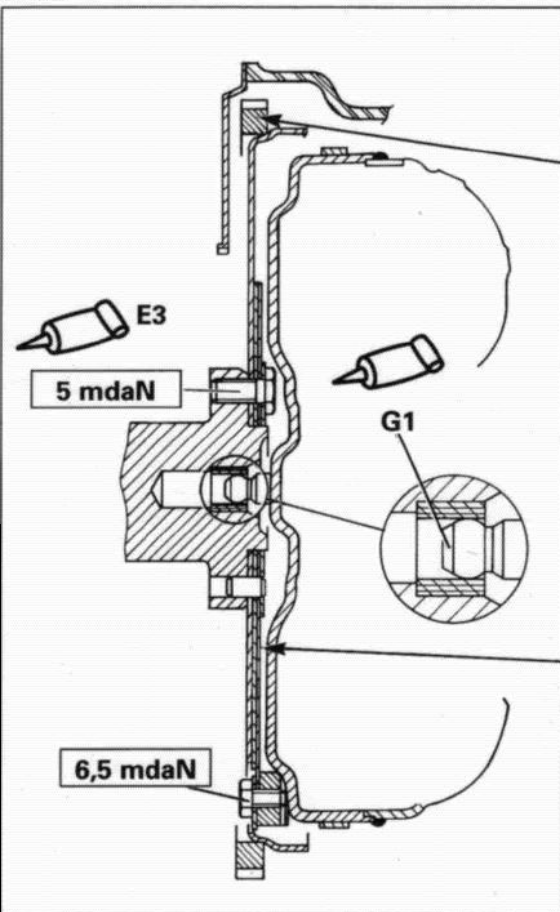

BX. 32-1

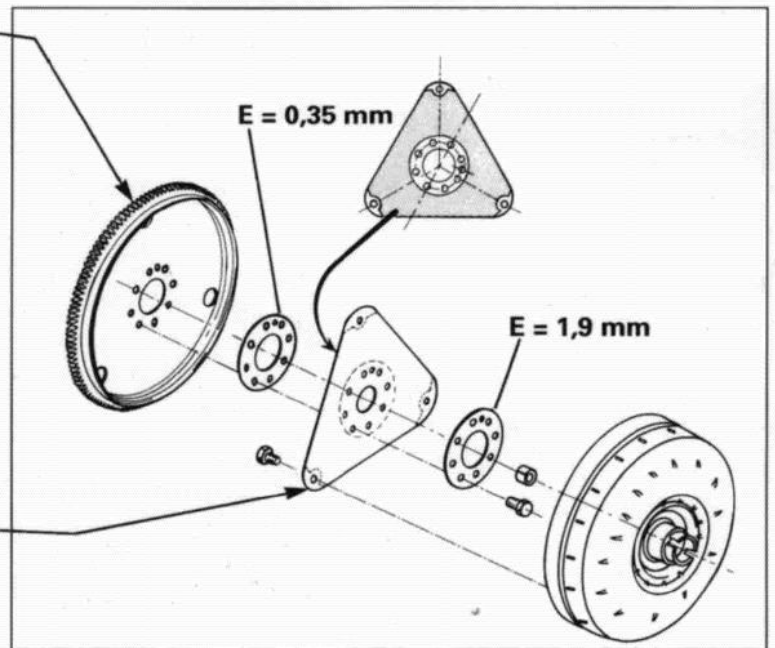

BX. 35.5